



SV SLURRY TANKERS

AWAKEN THE POWER OF YOUR NATURAL FERTILISERS

Reduce inorganic fertiliser costs: your slurry is worth its weight in gold!
Simplify your life by using resources from your farm.

Applying natural fertiliser is the perfect combination of efficiency and cost-effectiveness. Returning organic materials to the soil will naturally accelerate your crops' growth thanks to its nutrient content.

Tailoring our machine to your needs is our philosophy. Your business is changing, and so is ours. Every day, we solve your challenges. We develop and design ever more effective equipment to maximise the use of natural fertilisers.

Our history and track record are proof of our expertise. This experience continues to strengthen our reputation around the world.

Your requirements for tomorrow are our ambitions for today.



SLURRY TANKERS

PICHON SV

1 - SV design	04
2 - Preconfiguration	10
3 - Safety and driving comfort	12
4 - Slurry mixers	14
5 - Filling solutions	15
6 - Unloading pipe	16
7 - Application techniques	17
8 - Controllers	18
9 - Interfaces for implements	20
10 - Main options	22
11 - Technical data	24
12 - Services	26

ONE WORD : VERSATILITY

OPT FOR A FUTURE-PROOF TANKER

Available in single- and twin-axle versions, our SV models' design ensures their versatility. The tank is predefined as standard and includes a wide range of pre-fittings. This allows you to adapt your machine's features to the way your work progresses.

The SV range was developed after careful consideration. For several months, our project team, composed of engineers, designers, technicians, product managers and sales representatives, worked to create a range with one objective: offering you the best!

TECHNOLOGY THAT KEEPS ITS PROMISES

Vacuum technology creates a difference in atmospheric pressure between the inside of the tank and the ambient pressure. The vacuum within the tank sucks the slurry in regardless of the pit's configuration. Easy to use, this technology ensures safe and efficient operation, reaching a maximum negative pressure of -0.9 bar when filling and a maximum positive pressure of 1 bar when unloading. Wear and maintenance costs are reduced as no slurry enters the pump. All our tanks comply with the Pressure Equipment Directive (PED).



INVEST IN RELIABILITY



STURDY AND DURABLE

Our tankers have a robust steel structure combines with a galvanized finish. The tanker's interior and exterior are treated to provide continuous protection against the most aggressive elements. Our tankers are designed to work every day in tough conditions for many years, requiring only routine maintenance. Opt for long-lasting performance



EUROPEAN HOMOLOGATION

After two years of preparation, field tests, and external assessments, we have obtained European homologation for our vehicles. By choosing an EU-approved machine, you get a certificate of conformity (COC). It allows you to register your vehicle and use it on the European market with complete confidence. Our vehicles meet the highest European quality and safety standards.



SECURE ROAD ROUTES

Our tankers comply with the EN707 standard. They are fitted with baffles and baffle plates, guaranteeing optimum stability for your unit. This design makes your road journeys safer and improves driving comfort when travelling at high speed.



DIMENSIONS THAT FIT EVERYWHERE

COMPACT AND VERSATILE

Our single-axle slurry tankers, range from 6 to 12 m³, are versatile. Making them suitable for small and medium sized farms. Their compact, streamlined design makes them a great restricted spaces. The integrated chassis lowers the centre of gravity for optimum stability on slopes. Our single-axle models are particularly well-suited to the challenges of applying organic materials evenly on hilly or mountainous terrain. The design makes it especially easy to handle and a great all-rounder.

STABILITY AND COMFORT

The wheels are recessed as standard on the SV8R and SV12R models, allowing for large-diameter tyres to be fitted. The wider contact surface reduces soil compaction. The moveable axle distributes the weight evenly across the implement mounted onto the rear of the tank. The recessed wheels combined with the multi-positional axle provide enhanced stability thanks to a low centre of gravity. The total width remains less than 3 metres, and the maximum load complies with current legislation. This feature improves driving comfort.



“ Our aim is to offer machines and technologies for applying natural fertilisers to professional users that take the **environment and the people** into account ”

IDEAL FOR HILLY TERRAIN

DISCHARGE ON SLOPES

Our slope application system allows the tanker to be unloaded both uphill and downhill. Available as an option, the automatic weight transfer system ensures optimum load distribution on the drawbar and minimizes traction effort on slopes. This system ensures that the unit is stable on all types of terrain. The implement's slurry supply is constant, ensuring a uniform application.

REACH THE UNREACHABLE

A rain gun kit is available for the upper unloading pipe. This high emissions solution is only recommended in limited cases. The rain gun makes it possible to reach areas that the tractor cannot, which is a common occurrence for fields in mountainous or hilly regions. Although not its primary use, the rain gun option can be useful in more specific situations, such as putting out forest fires or water spraying.



ASSISTANCE ON SLOPES

The optional ALTA system automates the selection of front or rear unloading pipe reducing driver fatigue. The inclinometer installed on the tank gives a real-time reading of the slope. This information transmitted to the iControl7S terminal activates unloading mode based on the terrain's degree of inclination without any manual intervention. This innovation ensures complete tank unloading and even application on all types of slopes.

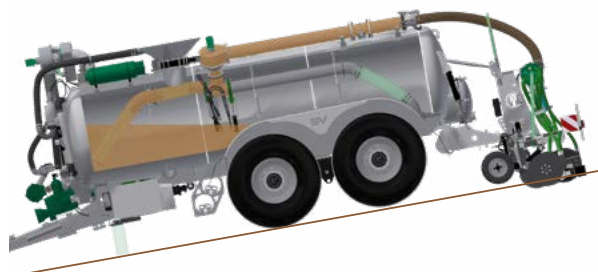
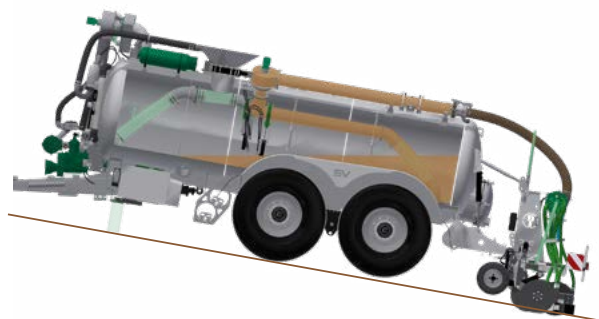

YOUR CHOICES TODAY...

MACHINES FOR THE FUTURE

The world of agriculture is constantly changing. With this in mind, we're bringing you retro upgradeable equipment capable of meeting your new daily challenges to market.

The SV tank comes with a wide range of pre-fittings as standard. They allow you to easily add new options as original equipment or retrofit.

The pre-configuration of SV models is compatible with our implements: drag hose booms, trailing shoe booms, injectors and incorporators. These lower emission techniques maximise the availability of nutrients and increase your yields.

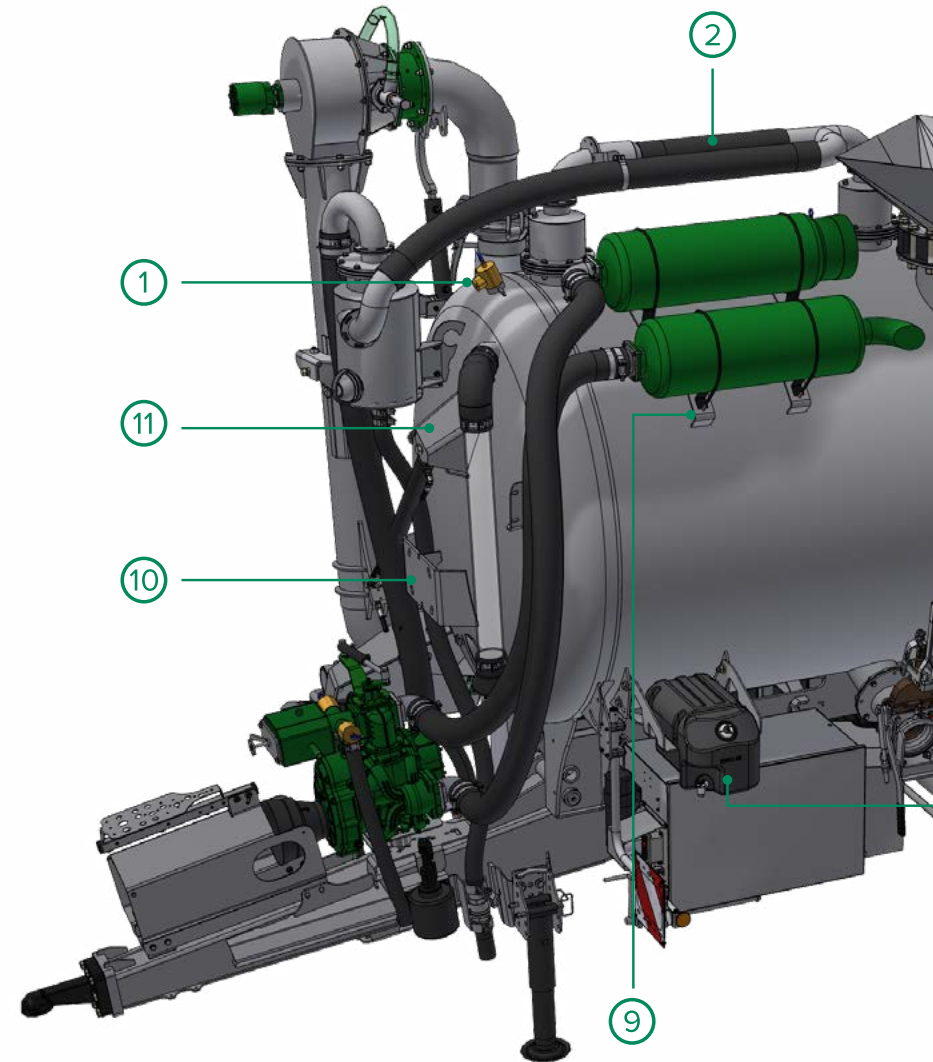

** Pre-equipment available according to model*

...SHAPE THOSE OF TOMORROW

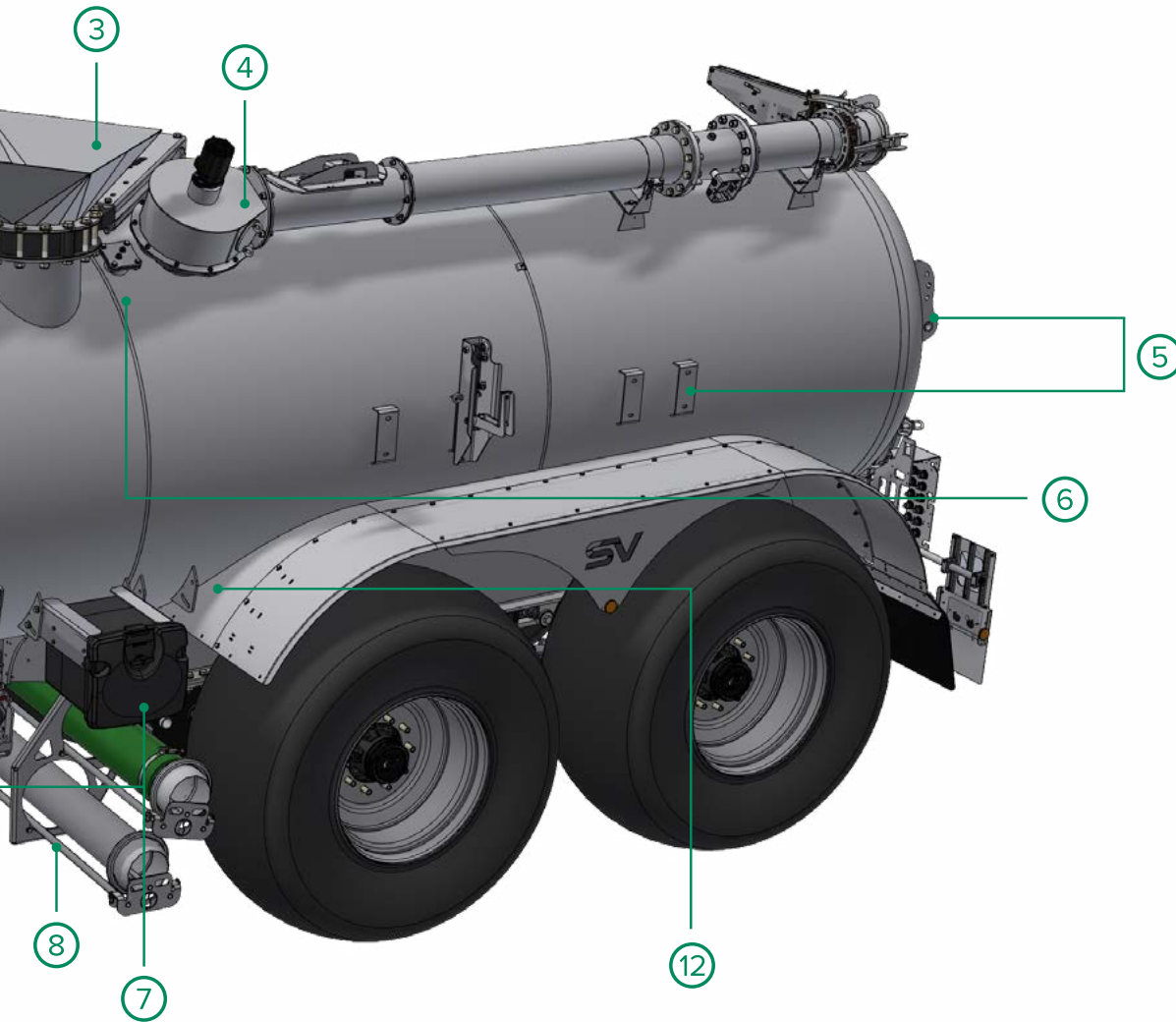

- ① PED pressure relief valve
- ② Weight transfer system / p.7
- ③ External filling
- ④ Drain pipe / p.14
- ⑤ Coupling / Brackets
- ⑥ ALTA slot / p.7
- ⑦ Toolbox and hand-wash basin
- ⑧ Pipe transport tray
- ⑨ Filter and silencer slot for lobe pumps
- ⑩ BP2 slot / p.13
- ⑪ Plunger arm slot / p.13
- ⑫ Automatic greasing slot

THE PLEASURE OF DRIVING

ONE AXLE WITH MULTIPLE BENEFITS

We have validated an innovative design for our single-axle models. This is an axle with a one-piece tubular structure and no welding. This design enhances the safety, endurance and performance of our vehicles. The structure is optimised so that stresses are distributed appropriately. This technology significantly reduces the weight of the axle when compared with a solid one. This saves a significant amount of weight, reducing the total weight of our machines. The uniqueness of this design ensures lower maintenance costs and longer axle life.

A WIDE SELECTION OF RUNNING GEAR

- **Mechanical suspension with connecting rods** are renowned for their strength and endurance. They support heavy loads and make driving on the road and in the field comfortable
- **The tandem with multi-leaf suspension** (*overslung or underslung assembly*) ensures excellent stability on hilly terrain. Load distribution is optimal even when implements are mounted. Efficient in extreme conditions, the tandem requires very little maintenance.
- **Bogie suspensions with parabolic leaf springs** combine versatility and efficiency. Their extensive articulation ensures excellent field ability.



EFFORTLESS DRIVING

Optimise manoeuvrability and reduce tyre wear by choosing steering with (a) steering axle(s) or forced axle(s). As standard, we offer a steering axle with controlled hydraulic locking from the tractor. As an option, axle units can be fitted with a forced steering axle. It provides autonomous steering without driver intervention, even at high speed or when reversing. It requires no hydraulic connection to the tractor and minimises stress on the vehicle during sharp turns.

YOUR SAFETY GUARANTEED

The dimensions of the brakes is based on the load, speed and wheel diameter. We have optimised the braking systems to cover current homologation and future standards.

ADAPT YOUR TYRE PRESSURE

Available as an option, tyre pressure regulation allows you to adjust tyre pressure in the field and on the road. The surface area is increased, reducing pressure and soil compaction. This ensures minimal soil damage and maximises the infiltration of nutrients to the roots. Adjusting your tyre pressure ensures good roadholding and reduces fuel consumption by limiting rolling resistance.



PREPARE SLURRY

MIXING SLURRY: THE KEY TO SUCCESS

Slurry varies in consistency depending on the farm. Some, such as those from poultry, pigs or cattle, have a high dry-matter content, which makes them difficult to pump.

Pit storage is divided into three layers. The sediment at the bottom of the pit is rich in nitrogen and phosphorus and has a high dry-matter content. Stirring the slurry in the pit is essential to homogenise and reactivate the bacterial life of its components. This optimises the slurry's effectiveness as a fertiliser, and also enables the tanker to be filled more quickly and efficiently before applying.

Our B-MIX slurry mixers, ranging from 5 to 10.5 m in length, are suitable for all pit types and can reach a depth of up to 6.5 metres. Entirely galvanised, their design facilitates maintenance and ensures that the mixer has a long service life.



Before mixing



After mixing



BP2 arm

ONE MISSION: MANY SOLUTIONS

From BP2, plunger, and turret arms to external filling systems (manual valves or top filling cone), you have plenty to choose from. Your PICHON SV is capable of filling all types of slurry and can be used in all pit configurations: below ground, above ground or covered.

CHOOSE SIMPLICITY (BP2)

The BP2 model fills slurry through a cone. Available in a Ø200mm version, it works on either the left or right side. This arm is easy to use and maintain. The turbo filler increases your output.

DIRECT ACCESS (PLUNGER ARM)

Access pits partially or completely below ground thanks to the two hydraulic articulations on the plunger arm. The robust plunger arm, Ø200mm as standard, has a reinforced structure. Thanks to its turbo filler on the articulation point, you can deal with the most difficult filling conditions.

A UNIVERSAL ARM (TURRET ARM)

Are you looking for versatility? This is the filling system for you! The rotation of the arm makes it compatible with all pit configurations: below ground, above ground or covered. It is fitted with a turbo filler on the articulation or submerged for maximum efficiency.



Plunger arm



Turret arm

INCREASE YOUR PERFORMANCE

PUMP/VACUUM PUMP

We offer two types of vacuum pump: eccentric rotor with radial vanes (air- or water-cooled) and volumetric lobe rotors (air-injecting cooling system). As standard, the 2-float filling safety device combined with the cyclonic cleaner protects the pump against the entry of liquid. This improves pump longevity and minimises maintenance costs.

TURBO FEEDER

The turbo feeder is ideal for users looking for flexibility. Driven by a hydraulic motor, it relieves the vacuum pump when unloading mode is activated. The feeder supplies the implement's vertical distributor and ensures quality distribution. This dual vacuum pump/feeder operation guarantees optimum performance with thick slurry from cattle, raw digestate, etc

AUTOMATIC DOSAGE CONTROL

The application rate in m^3/ha is set in the iControl 7S terminal's flow regulation module (p.17). The slurry flow rate is automatically regulated by a hydraulic valve at the application implement's inlet. Flow rate regulation is possible thanks to 2 settings: the instantaneous flow rate measured by the flowmeter and the speed measured by a sensor positioned on the tanker wheel. Apply the right dose in the right place at the right time.

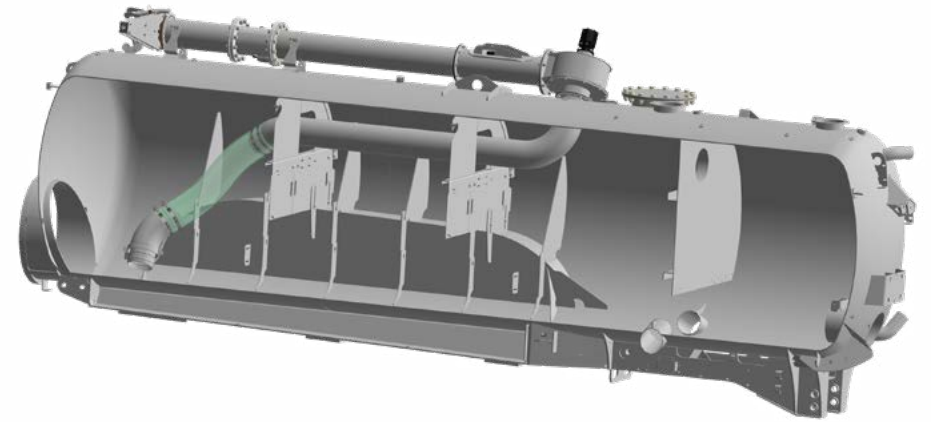

OPTIMISE THE USE OF NUTRIENTS

Tomorrow's agriculture must reconcile soil conservation and yields. To achieve this, you need precision and efficiency. With this in mind, we bring precision equipment designed to make the most of natural fertilisers to the market. We want to be by your side to contribute to sustainable agriculture.

Our surface application, injection and incorporation techniques optimize nutrient uptake by plants. They improve soil fertility and reduce ammonia emissions. In addition to improving air quality, they provide an effective supply of natural fertiliser to help the plot reach its maximum potential.

Application techniques	Models	Working widths
Drag Hose Boom	DHB1	9 / 12 / 12-15 / 15 m
	DHB2	12-15 / 15 / 15-18 / 18 m
Trailing Shoe Boom	TSB1	7,5 / 9 m
Arable Injectors	IDs	8 m
	EL71	4 / 5,70 m
Injector with discs	CDf	4,5 / 6 m
Injector with tines	EL61	3 / 4 / 5 / 6 m

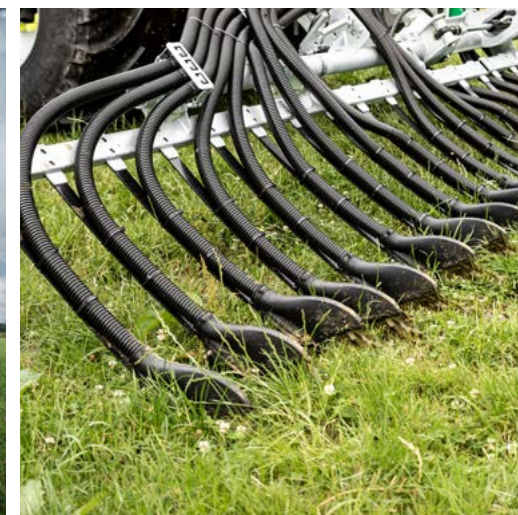

TECHNOLOGY AT YOUR SERVICE

EASIER OPERATION OF YOUR TANKER

The many technological advances made in the agricultural sector in recent years aim to improve operation traceability by recording data collected on the farm. Digital tools intended to achieve a balance of intensive and sustainable production. With this in mind, we develop Human Machine Interface (HMI) solutions designed to facilitate your day-to-day operations.

Our SV slurry tankers are equipped with our iControl control system. It is available in a manual joystick or joystick and touchscreen version. Its intuitive and ergonomic design has been crafted to make your filling, transport and application work easier. Entirely developed by our engineering department, we have mastered all the parameters to ensure reliable use and maintenance.



TPH system

Tractor Power Hydraulic

Steer your machine using your tractor's hydraulic valves without the need for an electronic control system.



iControl S (iCS)

Multi-function joystick

Simplify steering your tanker with the joystick. Work more comfortably and save time thanks to automated filling and application mode functions. The iCS joystick can carry out several functions, from opening valves to starting the turbo filler and positioning implements in work mode.

- Takes up minimal space in the cab
- Easy handling
- User-friendly
- Main machine function access



iControl 7S

iControl 7S (iC7S)

Joystick and 7" touchscreen

This intuitive, ergonomic controller lets you control your tanker at your fingertips. Increase your productivity by automating filling, transport and application cycles. View information about your operations in real time and collect yield data to optimise your application operations. Adjust input doses and save on mineral fertiliser. The joystick will give you access to all work functions within arm's reach.



iControl 7S: A UNIQUE TERMINAL DEFYING ALL COMPETITION

- Optimised touch surface (7" screen)
- Improved ergonomics and updated interface
- Simplified terminal settings
- Efficient machine steering and control
- Automated work cycles
- Real-time feedback on the screen
- Tracking and recording of operations carried out



PREPARE FOR THE FUTURE

For some years now, the emphasis has been on techniques for injecting and incorporating natural fertilisers into the soil. Among their many benefits, they reduce ammonia emissions and optimise crop yields. To prepare your equipment for these developments, we offer a range of coupling systems that allow you to add an implement as original equipment or retrofit.

PICHON UNIVERSAL LINKAGE

SV models are fitted with a linkage slot as standard. This interface is essential for connecting all PICHON implements. We recommend this option when you buy your machine to increase its versatility. Our universal linkage is compatible with all our application techniques: drag hose booms, trailing shoe booms, injectors and incorporators. To adapt the equipment to seasonal conditions and make your uncoupling/coupling operations easier, external linkage control is located at the rear of the tank.

FIXED SLOT SYSTEM

We also offer a fixed CATIII-category 4-point slot system compatible with our TSB1 trailing shoe boom. Its compact design is easy to install and includes basic hydraulic functions. This slot system increases the versatility of your tanker.

“ We develop and bring to the market application techniques to maximise nutrient utilisation by your plants. **We know that you need flexibility. For this reason, all our solutions are compatible with new or already in-service equipment.** ”



OPTIONS FOR MORE CUSTOMISATION



HOSE STORAGE

To make hose handling easier, we offer a storage system for 2 Ø150 or Ø200 hoses for certain configurations. It saves the operator time and effort.



TOOLBOX AND HAND-WASH BASIN

Access your tools, clothes or other accessories in a practical storage solution. A water tank with a soap dispenser is also available for washing hands and tools;



GREASING

To simplify servicing and reduce maintenance time, all greasing points are grouped together. An automatic central greasing system is also available to ensure precise greasing at regular intervals.



EXTERNAL FILLING

Ø400 hydraulic valve with cone to prevent splashing at the end of filling. Positioned at the front of the tank and clearly visible from the cab, this option allows the tank to be filled using an external pump and a filling crane without using the vacuum system

**Options available according to model*

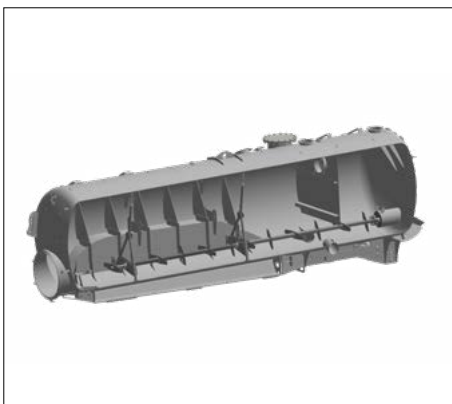

INTERNAL MIXER

The slurry is mixed from the front to the back of the tank to ensure that it is homogeneous when spread. This function prevents sedimentation of the product during transport.

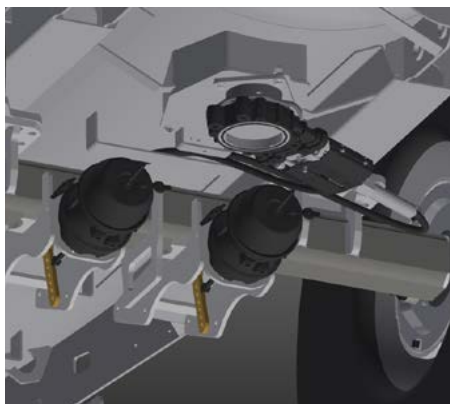

STONE TRAP UNLOADING

Foreign bodies are unloaded via a hydraulic valve located under the tanker. Operation triggered from the cab via the iC7S terminal or the tractor hydraulic.



DRAWBAR SUSPENSIONS

To meet users' needs and improve driving comfort, we provide passive or active hydraulic suspension. The active version allows you to adjust the height of the drawbar



PAINTED FINISH

Paint treatment (RAL 6029) for double external protection. The finish improves the machine's longevity and makes it easier to clean, particularly for liquid digestate from biogas plants.



TECHNICAL SPECIFICATIONS

		SV6	SV8R	SV10	SV12R	SV13	SV13R	SV15R	SV16	SV18R	SV20R
Capacity / Volume (L)		6 600	8 500	10 000	12 200	13 500	13 500	15 600	16 600	19 000	21 100
Lenght* (mm)	L	6 530	7 400	7 500	8 200	8 500	8 800	9 100	9 000	9 700	9 700
Diameter (mm)	Ø	1 400	1 500	1 600	1 700	1 700	1 700	1 800	1 800	1 900	2 000
Max. Height** (mm)	H	2 900	3 120	3 020	3 823	4 000	4 000	4 000	4 100	4 000	4 000
Min./max. width with wheels (mm)	B	2 340	2 550	2 800	2 900	2 900	2 915	2 915	2 850	2 915	2 915
		2 600	2 750	2 980	3 000	2 980	2 980	2 980	2 980	2 980	2 980
Track width (mm)	N	1 950	1 800	2 150	2 150	2 150	2 200	2 200	2 150	2 200	2 200
Min./max tare weight** (t)		2,8 / 3,3	4,4 / 5,4	3,9 / 5,2	6,3 / 9,5	8,5 / 9,5	9 / 12,2	10 / 12,3	8,5 / 10,5	11 / 12,5	11,5 / 13,3

*Length: Length without linkage

**Max. height: Max. height without implement

***Tare weight without equipment

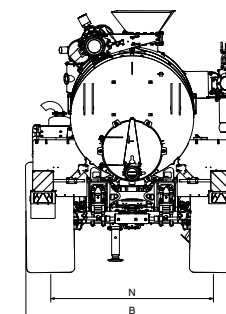
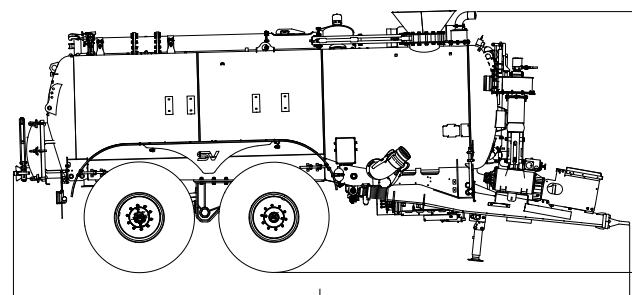
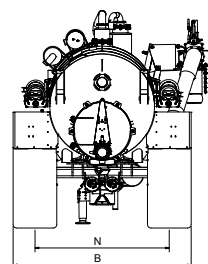
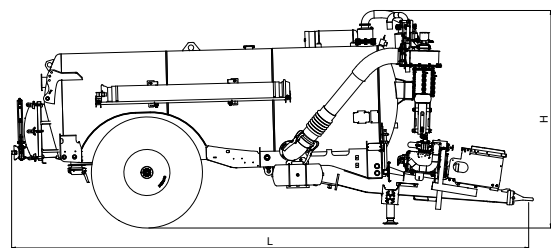

A RELIABLE NETWORK

PICHON MYPARTS

Our network of certified dealers has technical support and online documentation at their disposal via our MyParts platform. Spare parts catalogues, user manuals, technical booklets, assistance forms, warranty applications, etc.; they have all the tools they need to apply our manufacturer's expertise and provide you with an efficient after-sales service. Using your machine's serial number, our experts can find the machine's configuration details at the time of departure from our factories in just one click. This ensures that you receive original spare parts and guarantees longevity for your equipment

SPARE PARTS

Our warehouse and logistics departments ensure spare parts availability. They support and advise our distributors so that your equipment is maintained and repaired in the best conditions. Our network of dealers is on hand to meet your needs and order your spare parts as quickly as possible.





RESPONSIVE SERVICE

SERVICE-MINDED

Supported by our customer service department, our distribution network will accompany you from the moment your machine is commissioned. Our technical teams are available on the ground to train, advise and assist our dealers in order to guarantee you an efficient service. Our goal is to provide you with the best customer experience before, during and after your purchase.

PICHON ACADEMY

We take pride in training our network of dealers and their technicians in the use and maintenance of our machines. Our network of dealers will support you from the moment your equipment is commissioned and provide after-sales service. That's why we developed the PICHON ACADEMY training programme. This enables them to gain all the expertise necessary to help you get the most out of your PICHON equipment. Our distributors are on hand to advise you and provide you with our manufacturer's expertise.



PICHON_DOC-F050EN



SAMSON AGRO SASU - Boulevard André Malraux - 29400 LANDIVISIAU - FRANCE - Tel. : +33(2) 56 45 21 00

