



Severo Ochoa 13
Málaga (SPAIN)



+34 951 956 837



dhvtechnology.com

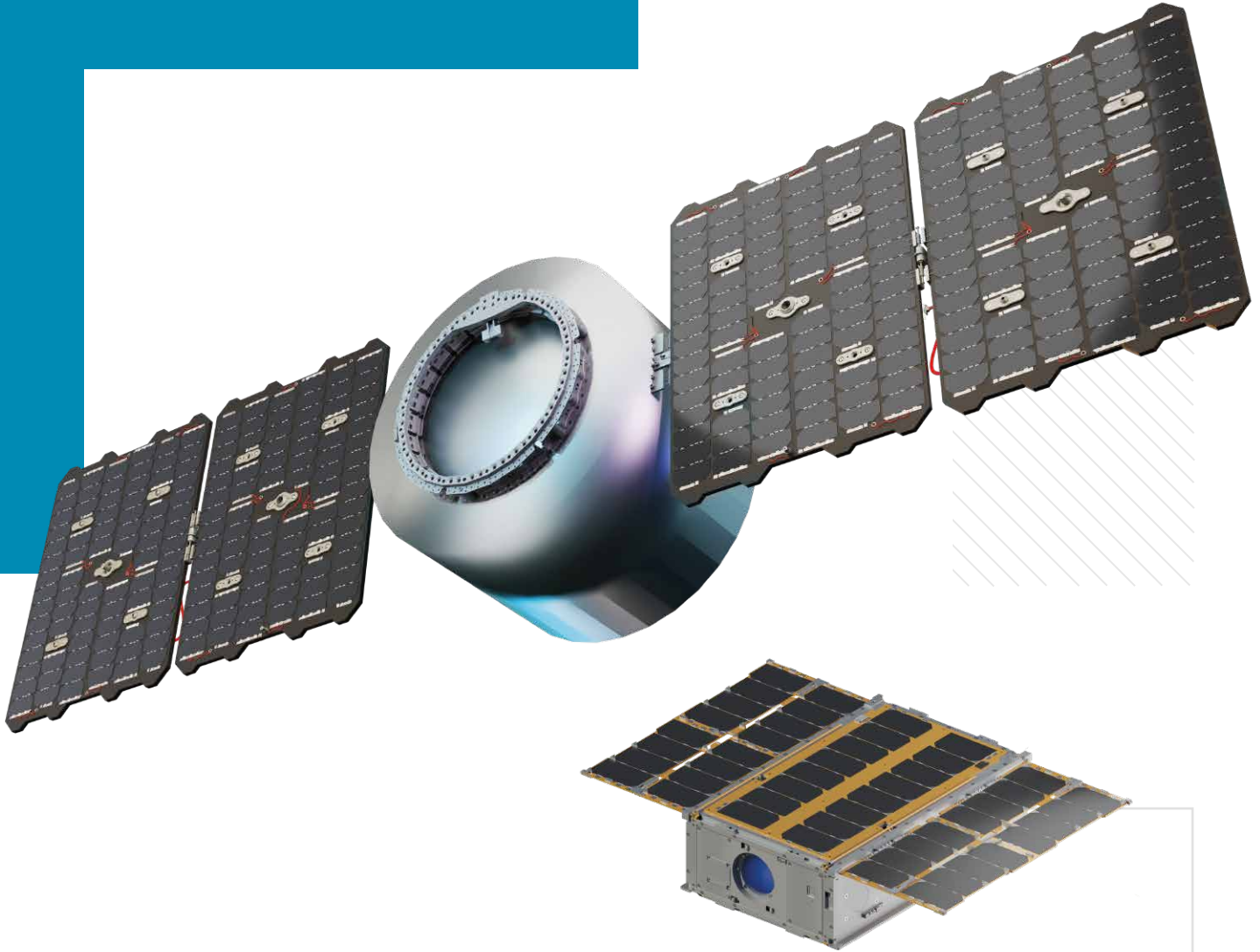

STANDARD SOLAR ARRAYS

Commercial off-the-shelf (COTS)
solar array solutions

Portfolio of standard solar arrays solutions

Deployable and body
mounted standard solar
array qualified solutions.



technology

CONTENTS

01	Smallsat COTS Solar Arrays	04
	▪ DSA-042W	04
	▪ BMSA-066W	04
	▪ DSA-079W	05
	▪ BMSA-050W	05
	▪ DSA-095W	05
	▪ DSA-108W	06
	▪ BMSA-087W	06
	▪ DSA-183W	07
	▪ DSA-185W	07
	▪ DSA-255W	08
	▪ BMSA-355W	08
	▪ DSA-373W	09
	▪ DSA-555W	09
	▪ DSA-676W	10
	▪ DSA-889W	10
	▪ DSA-1268W	11
02	CubeSat COTS Solar Arrays	14
	▪ BMSA-1U	14
	▪ BMSA-2U	14
	▪ BMSA-3U	14
	▪ BMSA-6U	14
	▪ DSA-3U-1D-L	15
	▪ DSA-3U-2D-L	15
	▪ DSA-3U-3D-L	16
	▪ DSA-6U-1D-L	16
	▪ DSA-6U-1D-S	17
	▪ DSA-6U-2D-S	17
	▪ DSA-6U-2D-L	17
03	About DHV Technology	18

Smallsat Solutions

• COTS Solar Arrays

Our portfolio of commercial off-the-shelf solar arrays for Smallsats are ready-to-market qualified solutions available for our customers to avoid the engineering related costs and reducing project timeline.

DSA-042W

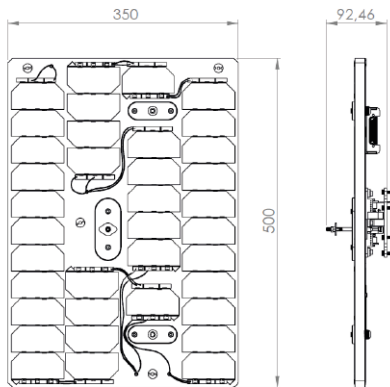

Total Power (BOL): **> 42W** (16s2p + 5s1p)
Panel type: **Simple Deployable Wing**
N° solar cells: **37** (AZUR 3G30A 30cm²)
Mass: **<1200g**

BMSA-066W

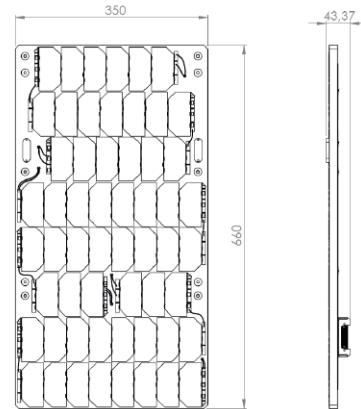

Total Power (BOL): **> 66W** (17s3p + 7s1p)
Panel type: **Body Mounted**
N° solar cells: **58** (AZUR 3G30A 30cm²)
Mass: **<1000g**

Example of both SA integrated in a S/C

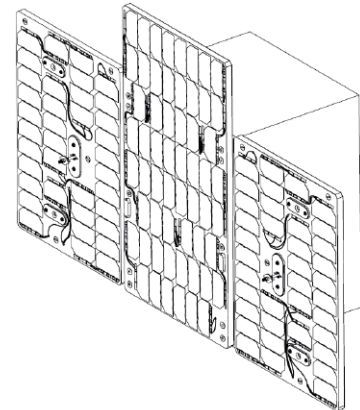
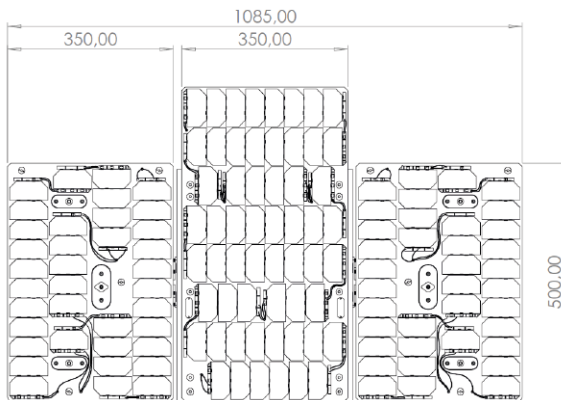

General Conditions

The general conditions applied for the power output of each COTS solution are listed below:

- 1AU mean Solar Flux (1367 W/m²)
- AM0 solar spectrum
- 28°C
- BOL

DSA-079W

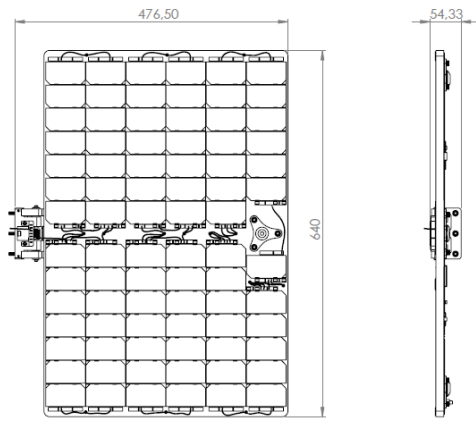

BMSA-050W

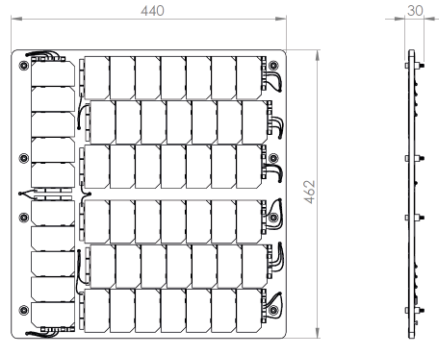

Total Power (BOL): **> 79W** (7s11p + 5s1p)
 Panel type: **Simple Deployable Wing**
 N° solar cells: **82** (AZUR 3G30A 26cm²)
 Mass: **<1800g**

Total Power (BOL): **> 50W** (7s6p + 5s2p)
 Panel type: **Body Mounted**
 N° solar cells: **52** (AZUR 3G30A 26cm²)
 Mass: **<800g**

Example of both SA integrated in a S/C

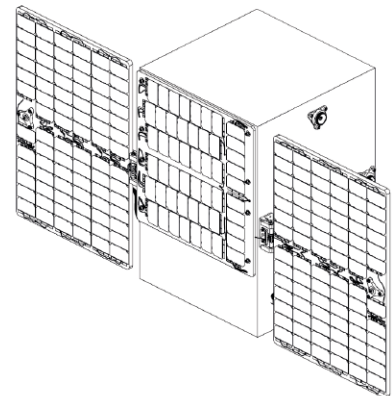
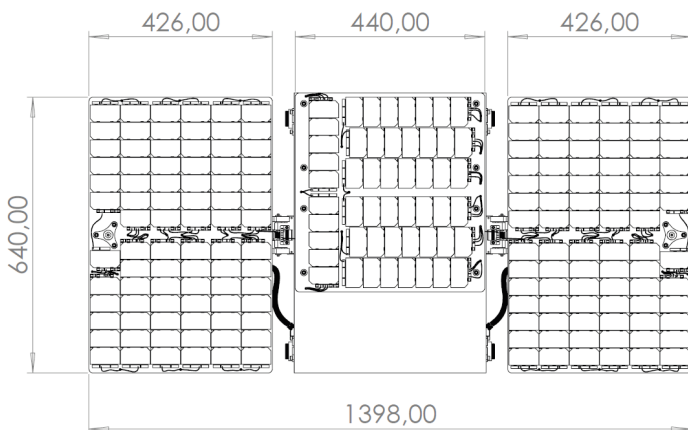

DSA-095W

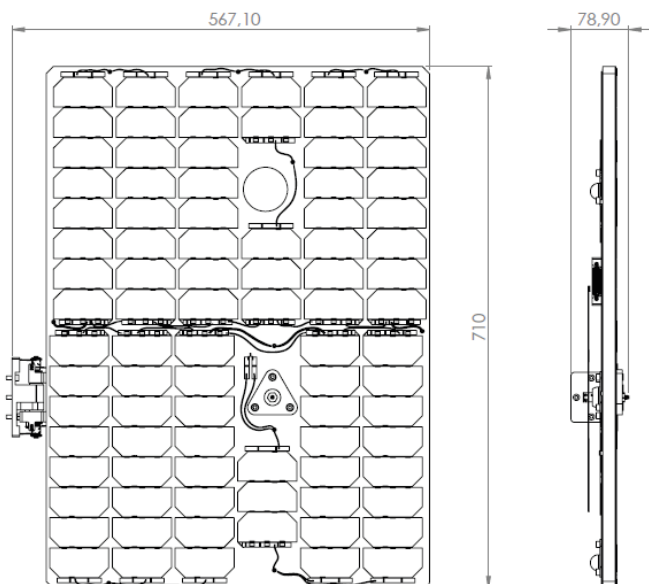

Total Power (BOL): **> 95W** (8s11p)
 Panel type: **Simple Deployable Wing**
 N° solar cells: **88** (AZUR 3G30A 30cm²)
 Mass: **<2200g**

Example of integration in a S/C

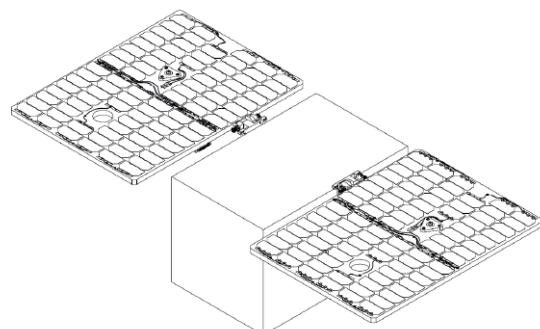

DSA-108W

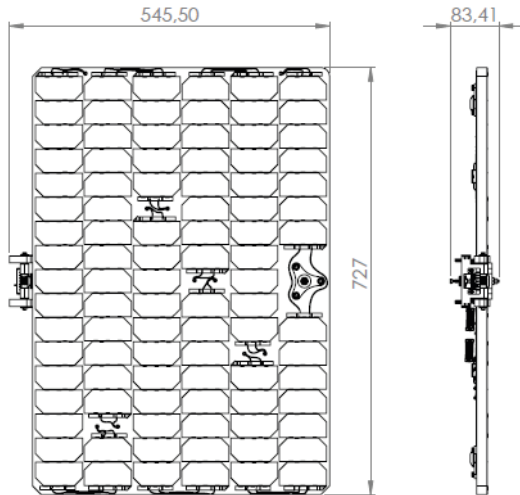

BMSA-087W

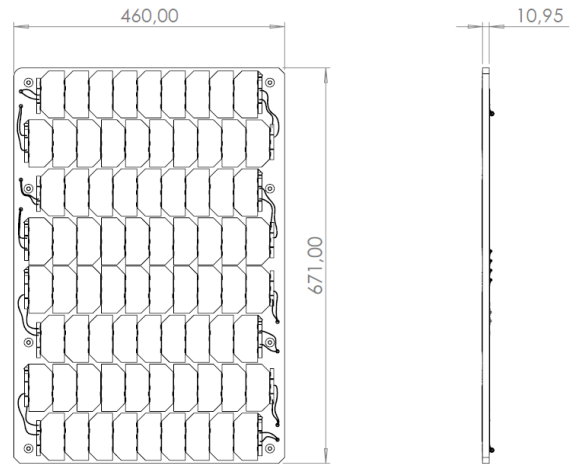

Total Power (BOL): **> 108W** (19s5p)
Panel type: **Simple Deployable Wing**
N° solar cells: **95** (AZUR 3G30A 30cm²)
Mass: **<2500g**

Total Power (BOL): **> 87W** (19s4p)
Panel type: **Body Mounted**
N° solar cells: **76** (AZUR 3G30A 30cm²)
Mass: **<1400g**

Example of both SA integrated in a S/C

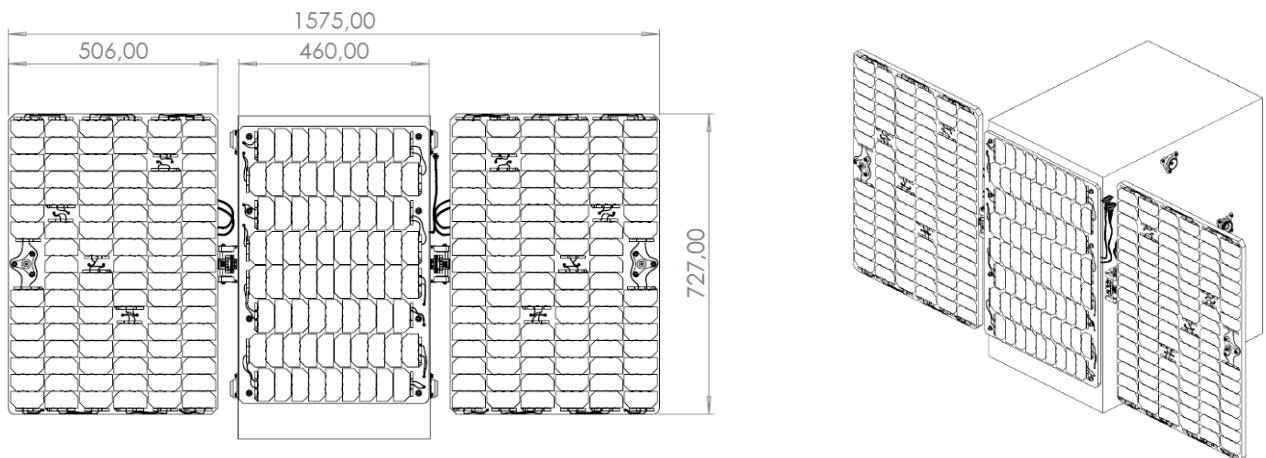

Loss Factors

Losses considered as nominal, always applied in all SmallSat designs:

- Blocking diode: 0,8V
- Current cell mismatch: 2,12%
- Calibration error: 3%
- Pointing error: 0,14%

Depending on the final mission, some additional electrical losses can be applied

DSA-183W

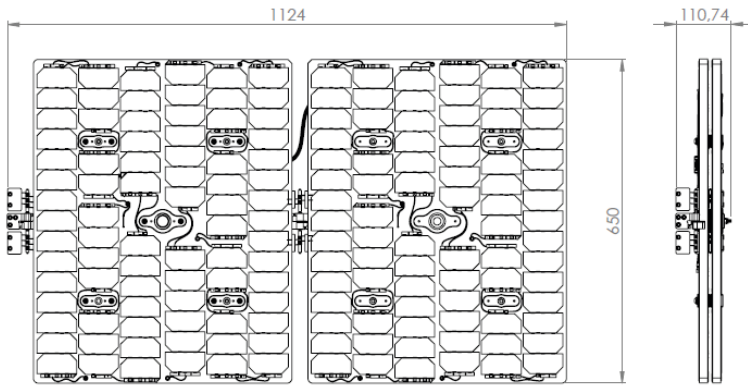

Example of integration in a S/C

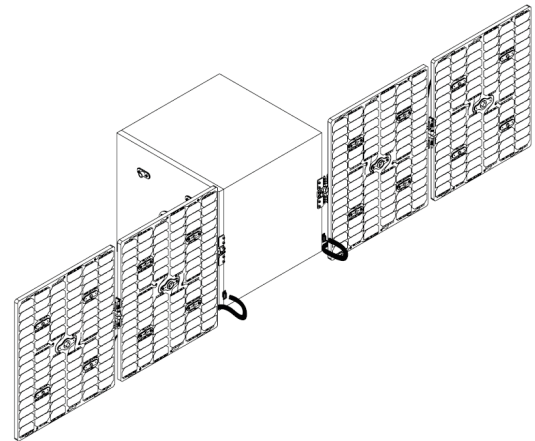

Total Power (BOL): **> 183W** (20s8p)
Panel type: **Double Deployable Wing**
N° solar cells: **160** (AZUR 3G30A 30cm²)
Mass: **<4300 g**

DSA-185W

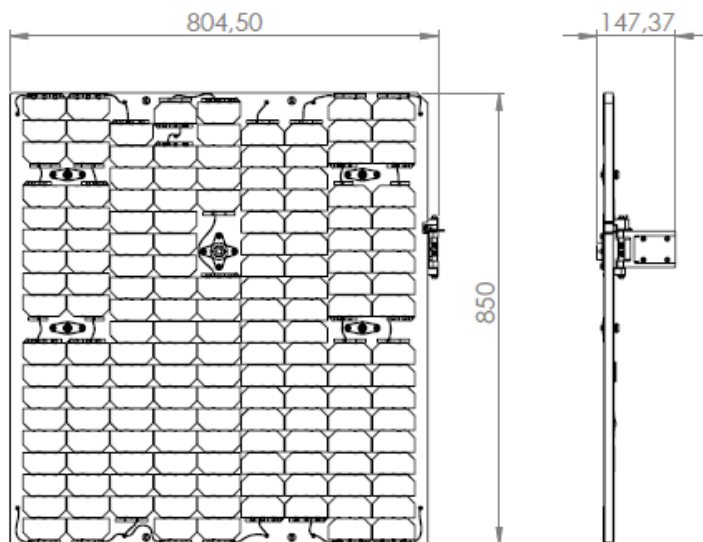

Example of integration in a S/C

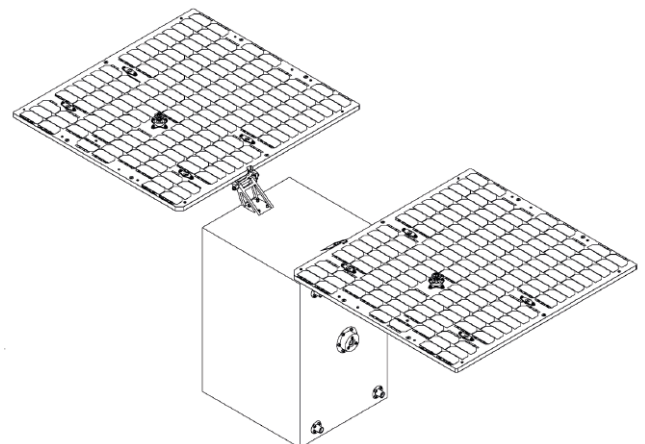

Total Power (BOL): **> 185W** (18s9p)
Panel type: **Simple Deployable Wing**
N° solar cells: **162** (AZUR 3G30A 30cm²)
Mass: **<3600g**

DSA-255W

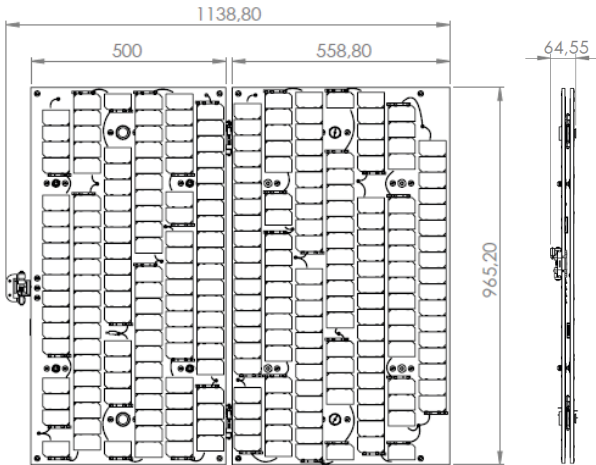

Example of integration in a S/C

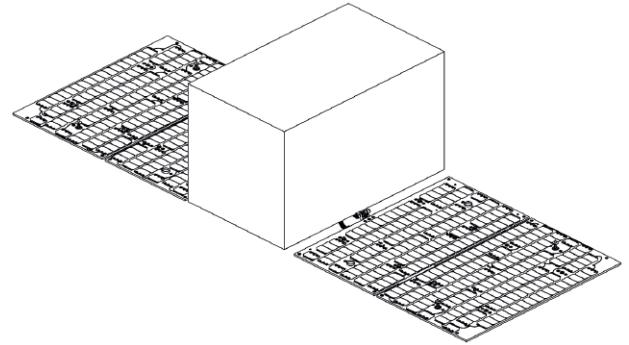

Total Power (BOL): **> 255W** (17s15p)
Panel type: **Double Deployable Wing**
N° solar cells: **255** (AZUR 3G30A 26cm²)
Mass: **<4300g**

BMSA-355W

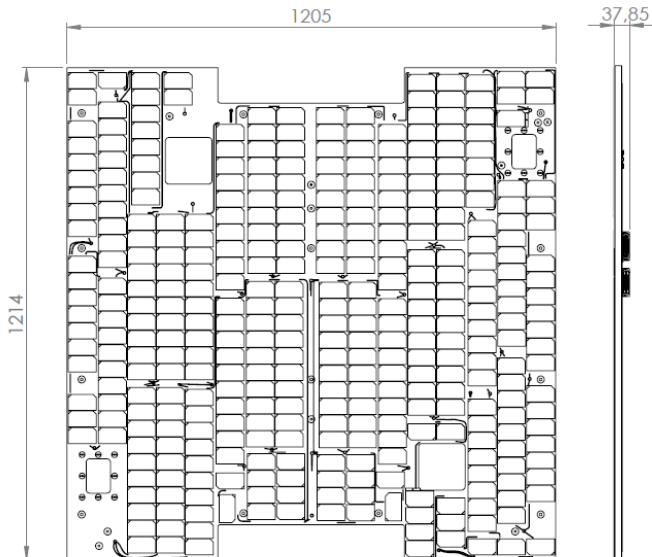

Total Power (BOL): **> 355W** (10s18p+10s19p)
Panel type: **Body Mounted**
N° solar cells: **370** (AZUR 3G30A 26cm²)
Mass: **<7000g**

Example of integration in a S/C

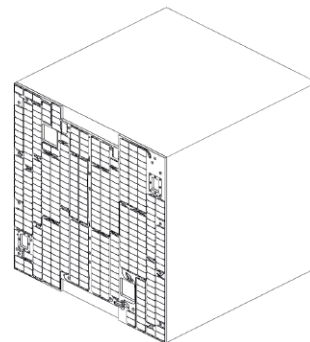

- Technical support within 24h
- Customization available under request
- 3D CAD files
- Integration with solar arrays
- 0g Deployment MGSE

DSA-373W

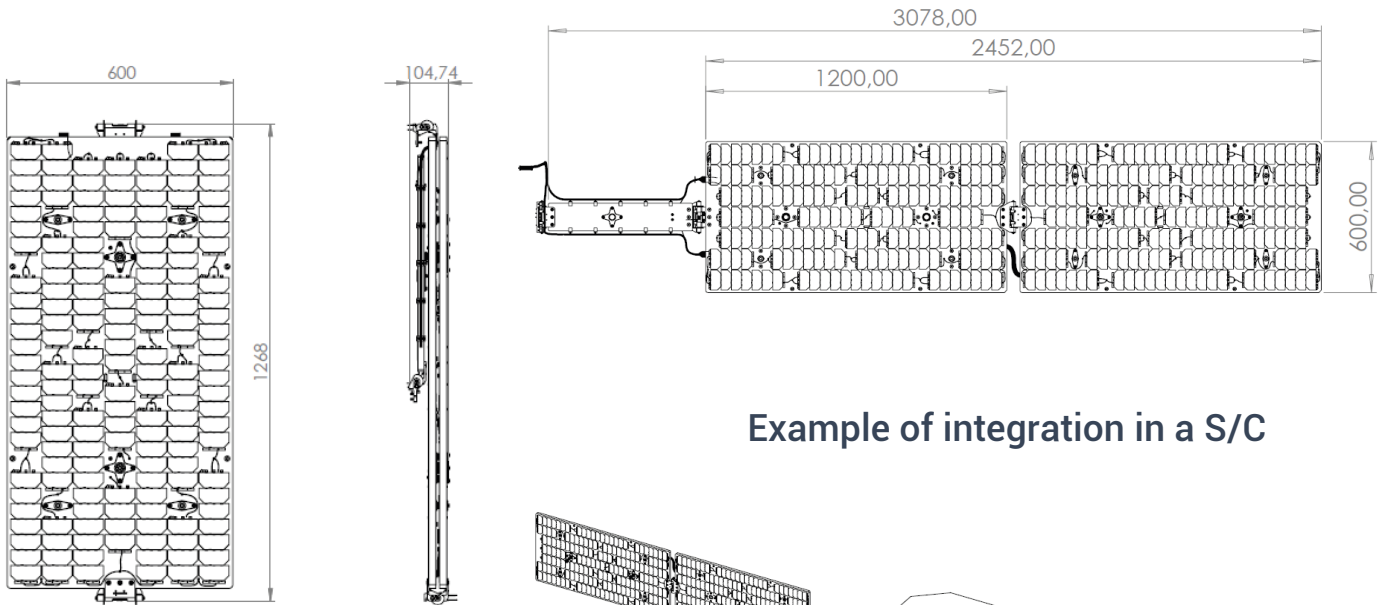

Example of integration in a S/C

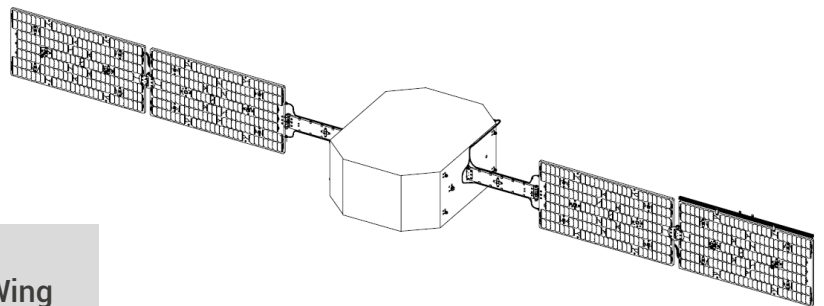

Total Power (BOL): **> 373W** (11s30p)
 Panel type: **Double Deployable Wing**
 N° solar cells: **330** (AZUR 3G30A 30cm²)
 Mass: **<12000g**

DSA-555W

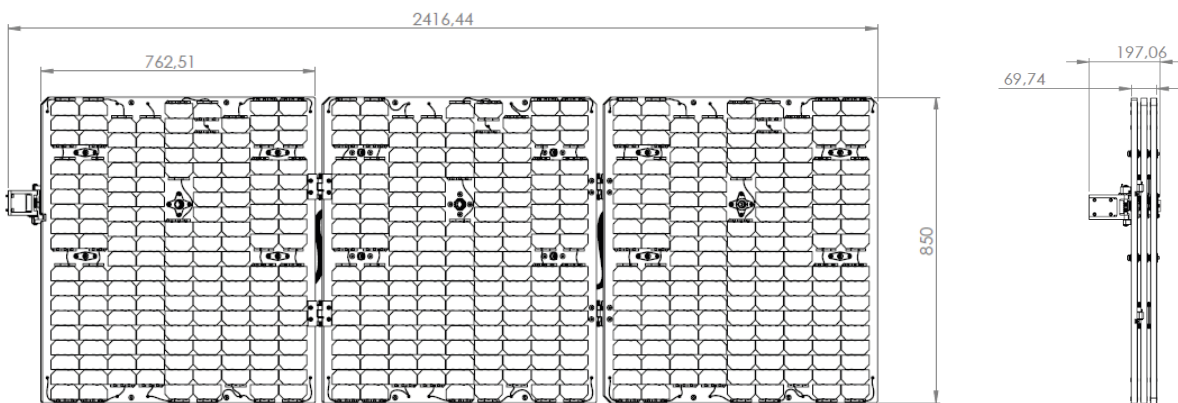

Example of integration in a S/C

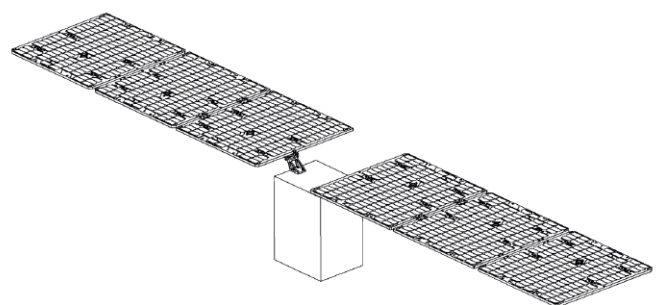

Total Power (BOL): **> 555W** (18s27p)
 Panel type: **Triple Deployable Wing**
 N° solar cells: **486** (AZUR 3G30A 30cm²)
 Mass: **<10000g**

DSA-676W

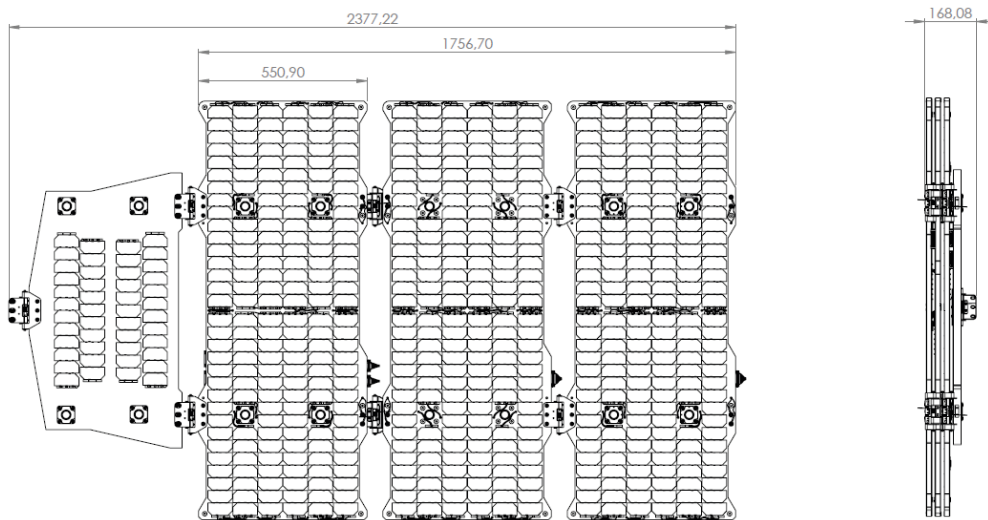

Example of integration in a S/C

Total Power (BOL): **> 676W** (23s26p)
 Panel type: **Quadruple Deployable Wing**
 N° solar cells: **598** (AZUR 3G30A 30cm²)
 Mass: **<20000g**

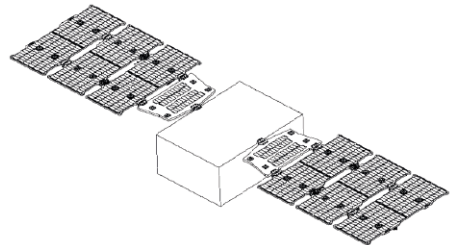

DSA-889W

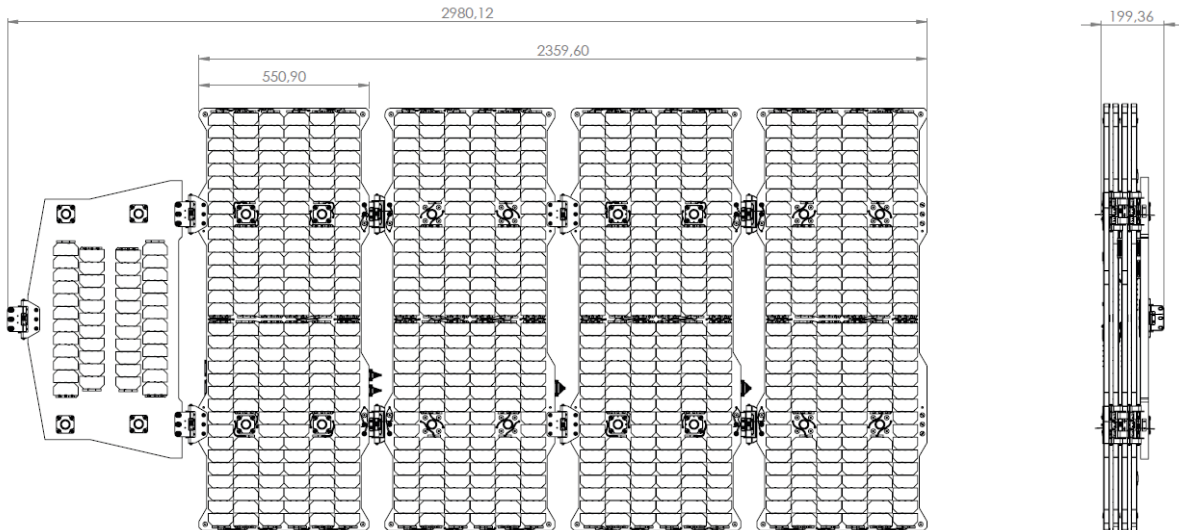

Example of integration in a S/C

Total Power (BOL): **> 889W** (23s34p)
 Panel type: **Quintuple Deployable Wing**
 N° solar cells: **782** (AZUR 3G30A 30cm²)
 Mass: **<24000g**

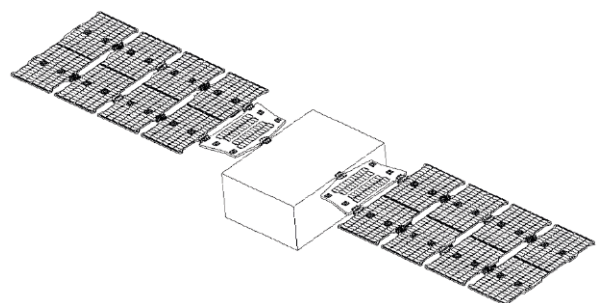

DSA-1268W

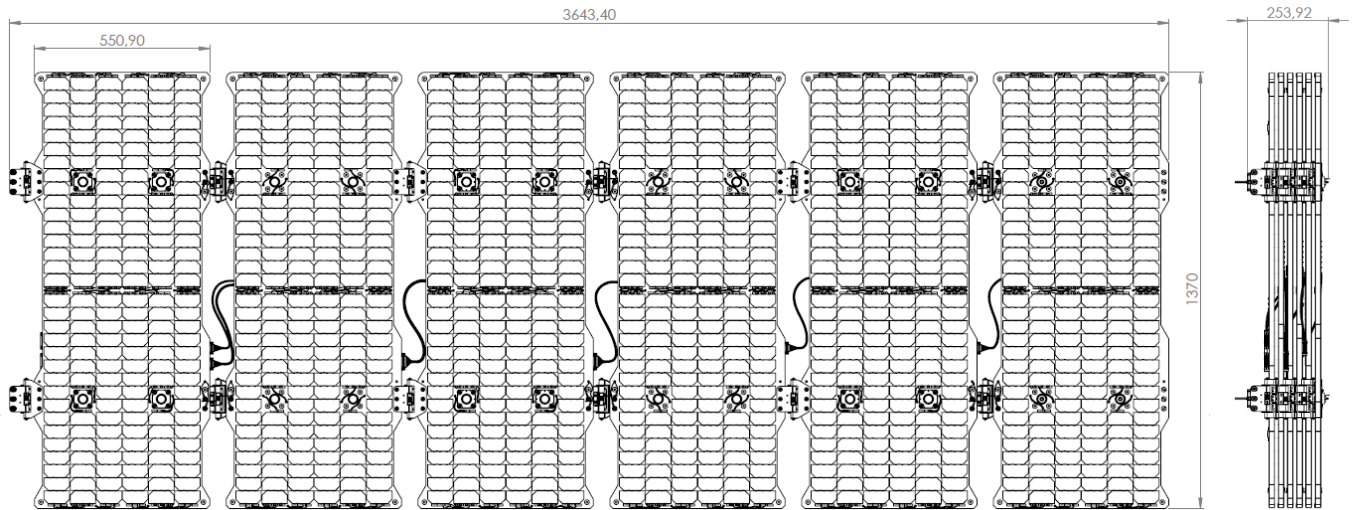

Total Power (BOL): **> 1268W** (23s48p)
Panel type: **Sextuple Deployable Wing**
N° solar cells: **1104** (AZUR 3G30A 30cm²)
Mass: **<32000g**

Example of integration in a S/C

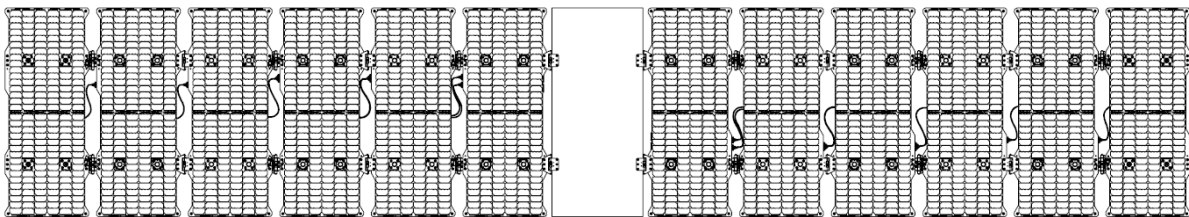
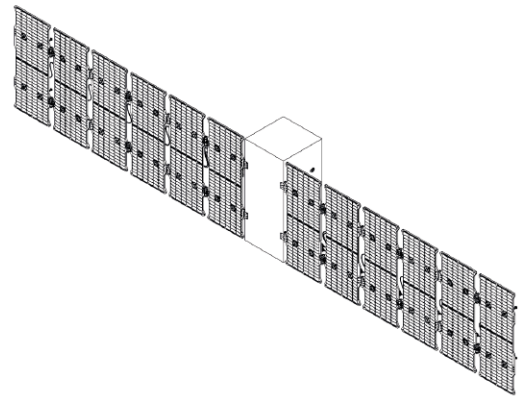

Key features

- Standard solutions without NRE costs
- Reduced costs and lead time
- Qualified solutions TRL8 ~ TRL9
- CFRP substrates with honeycomb core
- HDRM integration
- ATOX protection

Custom Solutions

- Tailor-made custom solar arrays

DHV Technology has extensive experience delivering customized solutions to meet our customers' platform and mission requirements.

Please feel free to contact our team at sales@dhvtechnology.com so we can analyze your project and propose a custom design tailored to your needs.

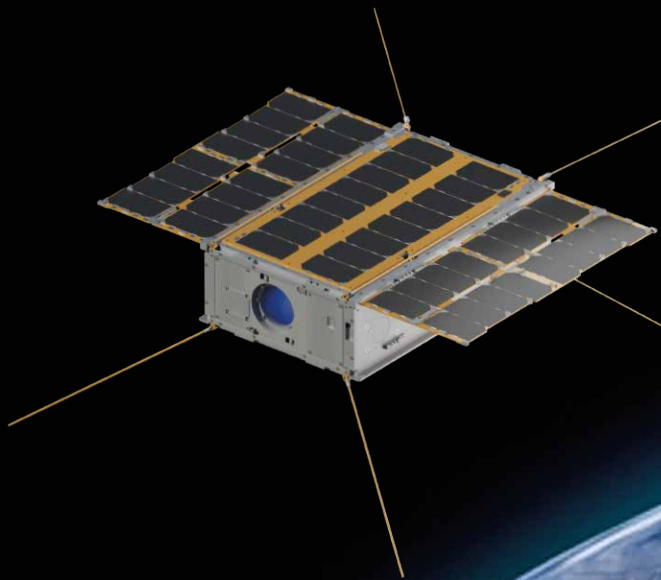
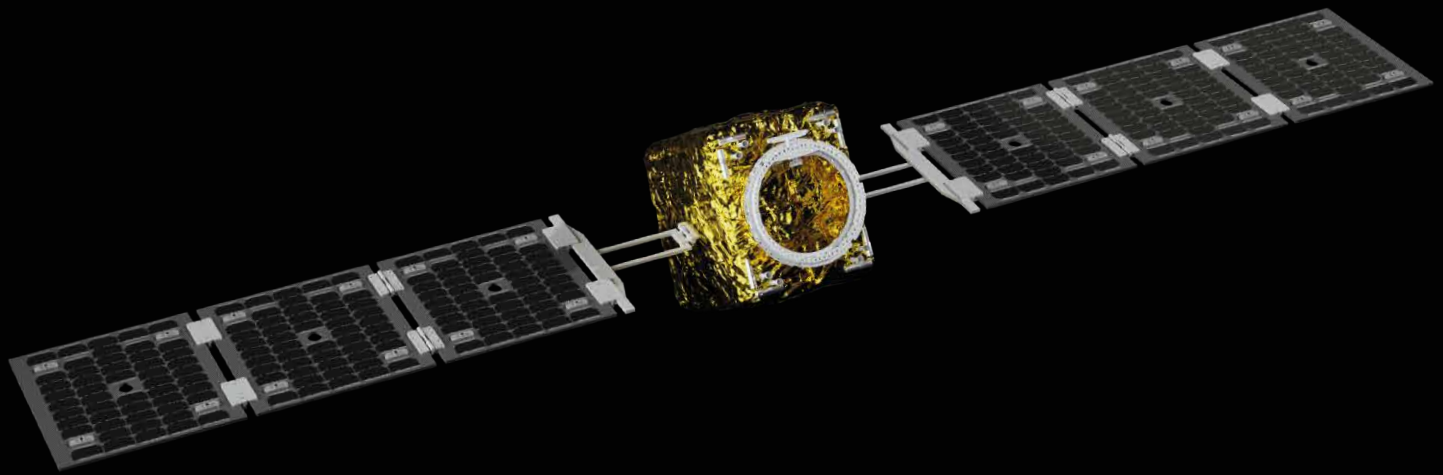

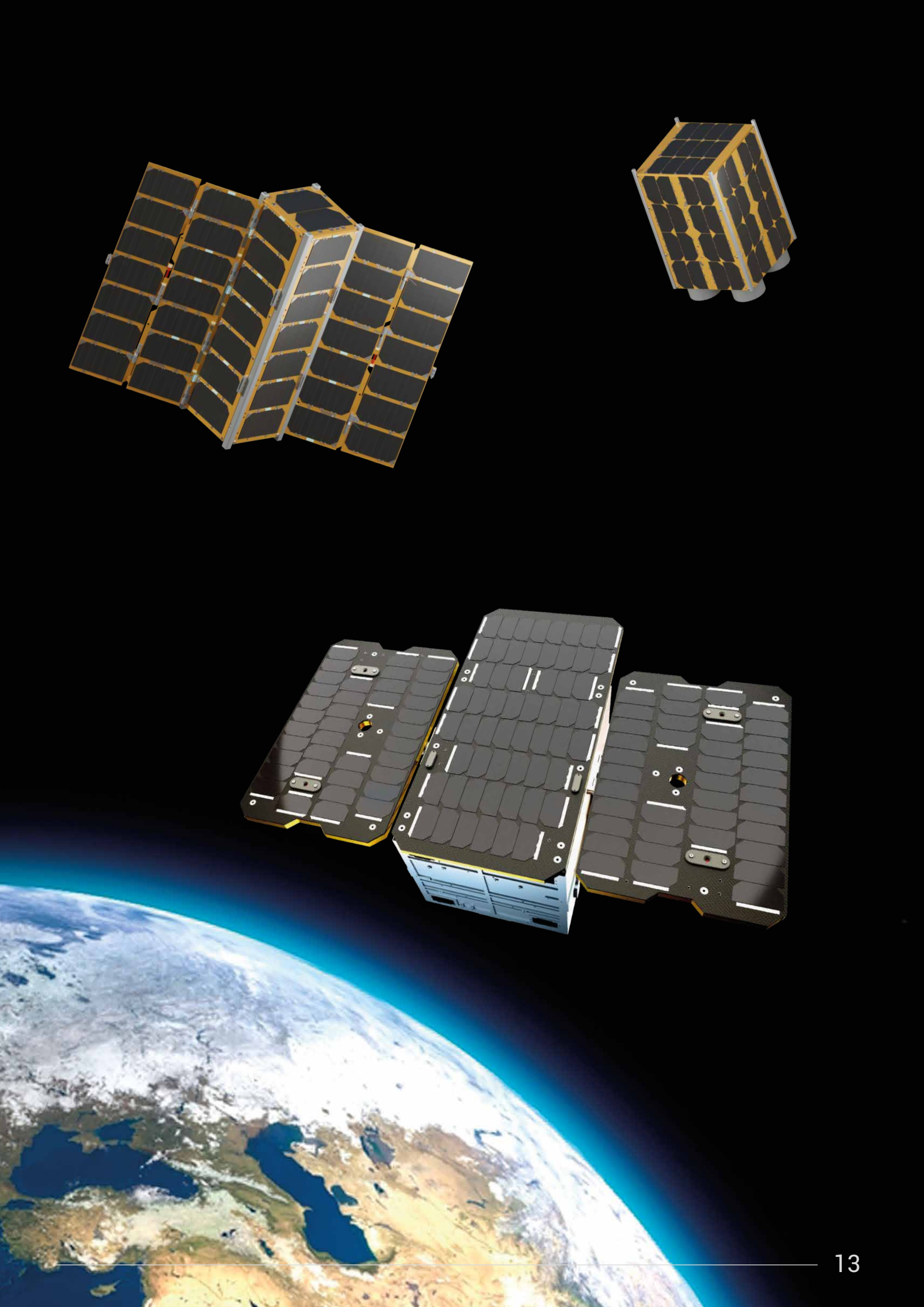

CubeSat Solutions

• COTS Solar Arrays

Our portfolio of commercial off-the-shelf solar arrays for **CubeSats** are ready-to-market qualified solutions available for our customers to avoid the engineering related costs and reducing project timeline.

BMSA-1U

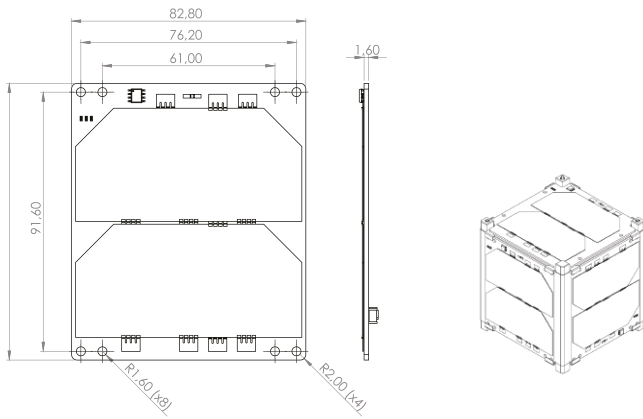

BMSA-2U

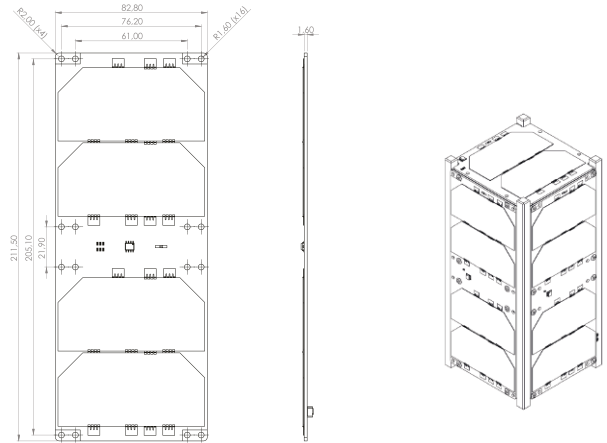

Wing Power (BOL): **> 2,07W** (2s1p)
 Panel type: **Body Mounted**
 N° solar cells: **2** (AZUR 3G30A 30cm²)
 Mass: **<50g**

Wing Power (BOL): **> 4,38W** (4s1p)
 Panel type: **Body Mounted**
 N° solar cells: **4** (AZUR 3G30A 30cm²)
 Mass: **<100g**

BMSA-3U

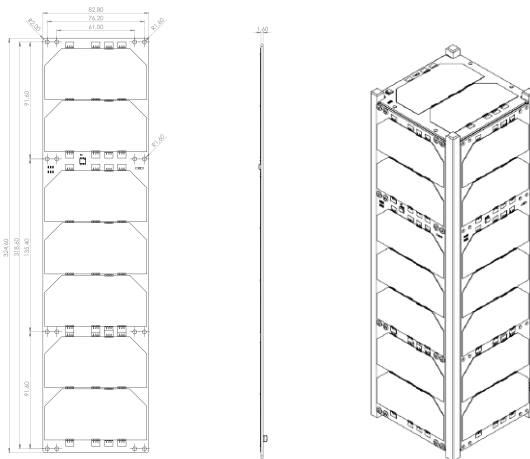

BMSA-6U

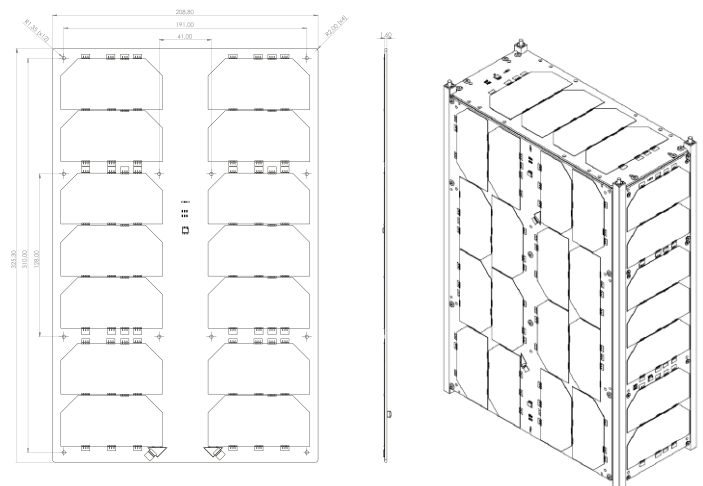

Wing Power (BOL): **> 7,84W** (7s1p)
 Panel type: **Body Mounted**
 N° solar cells: **7** (AZUR 3G30A 30cm²)
 Mass: **<140g**

Wing Power (BOL): **> 17,99W** (8s2p)
> 17,52W (4s4p)
 Panel type: **Body Mounted**
 N° solar cells: **16** (AZUR 3G30A 30cm²)
 Mass: **<300g**

DSA-3U-1D-L

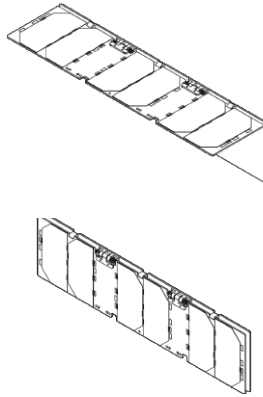
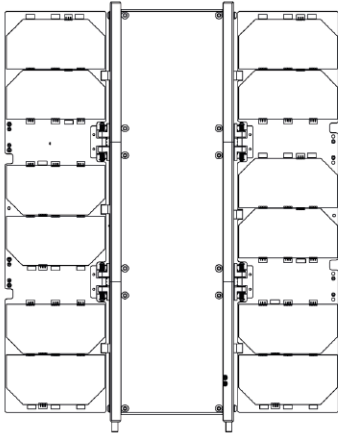

Example of integration in a S/C

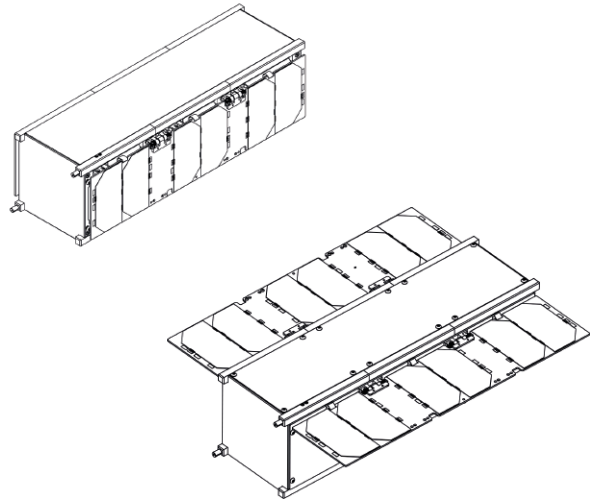

Wing Power (BOL): **> 6,64W** (6s1p)
Panel type: **Simple Deployable Wing**
N° solar cells: **6** (AZUR 3G30A 30cm²)
Mass: **<200g**

DSA-3U-2D-L

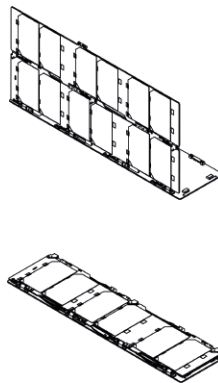
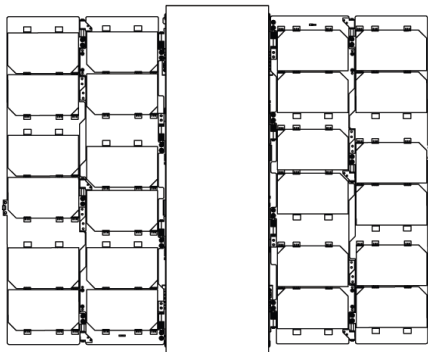

Example of integration in a S/C

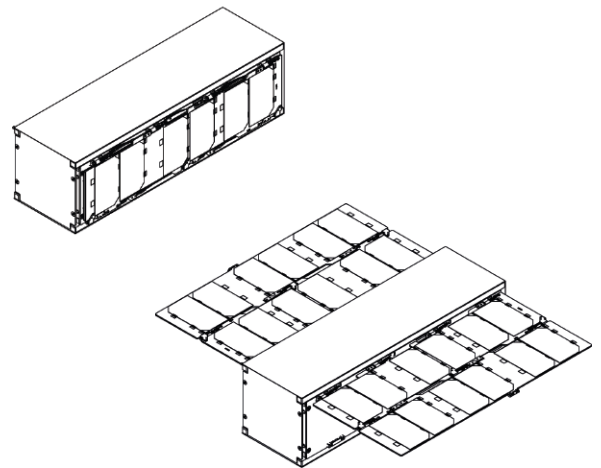

Wing Power (BOL): **> 10,64W** (2s6p)
Panel type: **Double Deployable Wing**
N° solar cells: **12** (AZUR 3G30A 26cm²)
Mass: **<300g**

Loss Factors

Losses considered as nominal, always applied in all CubeSat designs:

- Blocking diode: 0,6V
- Current cell mismatch: 2,12%
- Calibration error: 3%
- Pointing error: 0,14%

Depending on the final mission, some additional electrical losses can be applied

DSA-3U-3D-L

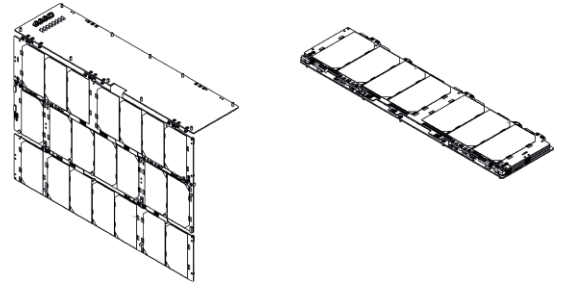
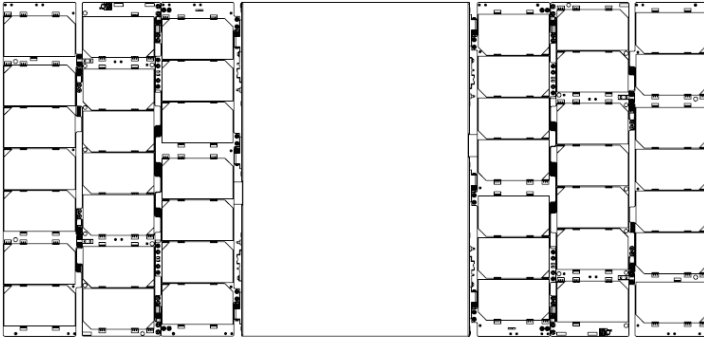

Example of integration in a S/C

Wing Power (BOL): **> 20,52W** (7s3p)
Panel type: **Triple Deployable Wing**
N° solar cells: **21** (AZUR 3G30A 26cm²)
Mass: **<450g**

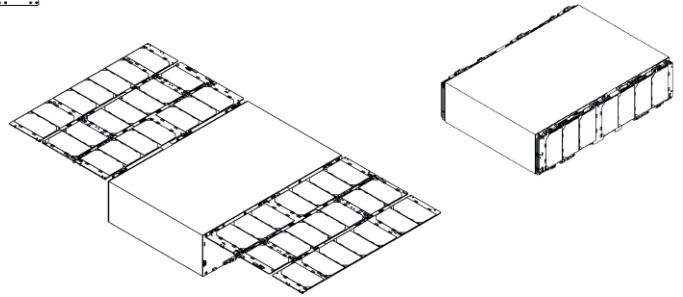

DSA-6U-1D-L

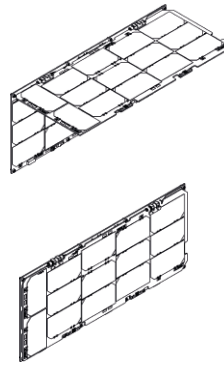
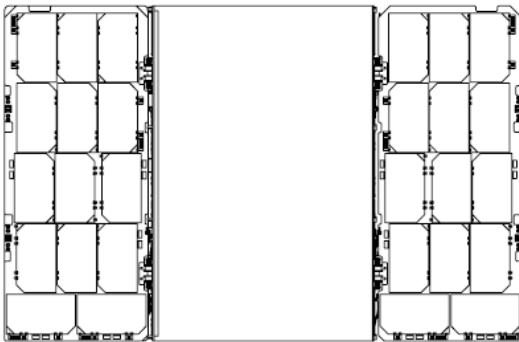

Example of integration in a S/C

Wing Power (BOL): **> 28,23W** (7s2p + 7s2p)
Panel type: **Simple Deployable Wing**
N° solar cells: **28** (Solaero ZTJ-Q 26cm²)
Mass: **<420g**

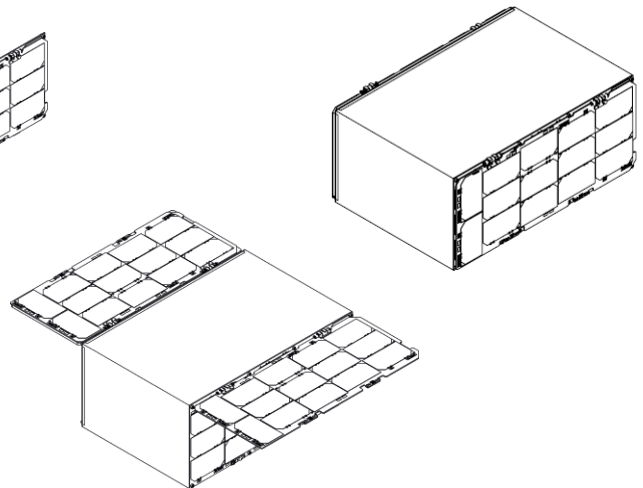

Key features

- Standard solutions without NRE costs
- Reduced costs and lead time
- Qualified solutions TRL8 ~ TRL9
- Polyamide PCB substrates with Kapton coverlay
- Thermal knife deployment system integration
- Temperature sensor integration

DSA-6U-1D-S

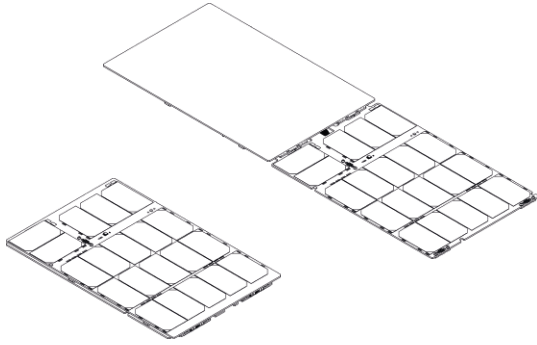

Wing Power (BOL): **> 19W** (4s5p)
Panel type: **Simple Deployable Wing**
N° solar cells: **20** (AZUR 3G30A 26cm²)
Mass: **<540g**

DSA-6U-2D-S

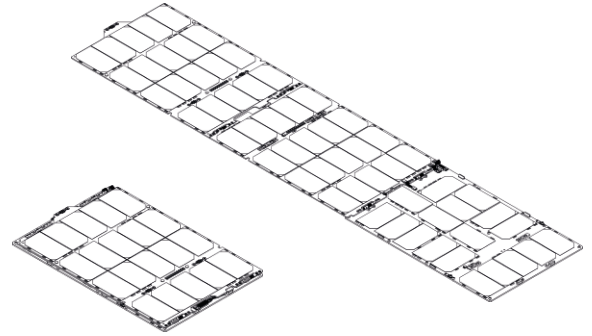

Wing Power (BOL): **> 54,72W** (4s10p + 3s6p)
Panel type: **Double Deployable Wing**
N° solar cells: **58** (AZUR 3G30A 26cm²)
Mass: **<820g**

Example of both SA integrated in a S/C

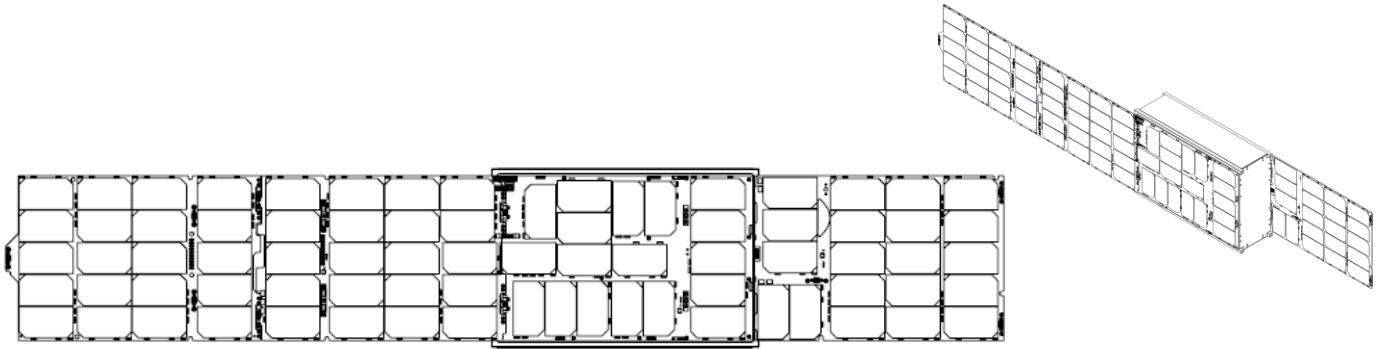

DSA-6U-2D-L

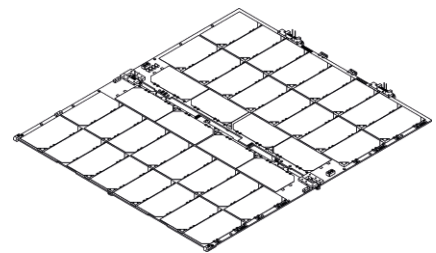
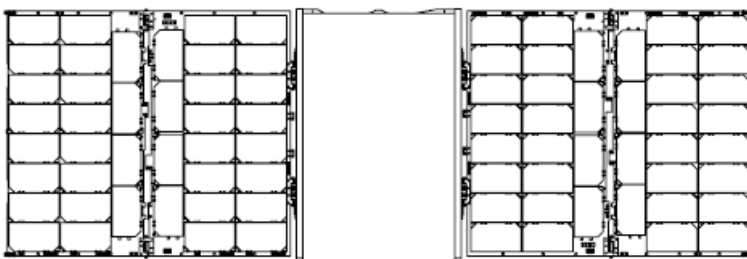

Example of integration in a S/C

Wing Power (BOL): **> 40,77W** (10s2p + 10s2p)
Panel type: **Double Deployable Wing**
N° solar cells: **40** (Solaero ZTJ-Q 26cm²)
Mass: **<620g**

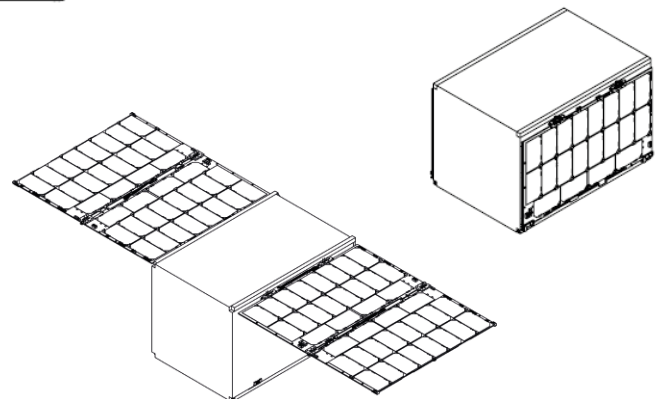

ABOUT US

DHV Technology is a Spain based international company that designs and manufactures solar panels for space applications and other power subsystems for different platforms.

DHV Technology has been providing tailor-made solar arrays systems to different international companies at the same time the company has been developing different power subsystems implementing the most advanced technologies.

Our facilities, with a total of 3700 m², consist of:

- 1200 m² clean room
- 1000 m² offices
- 1500 m² warehouse and others



350+

Projects completed

4000+

Days in orbit

400+

Satellites flying
with our solutions



technology

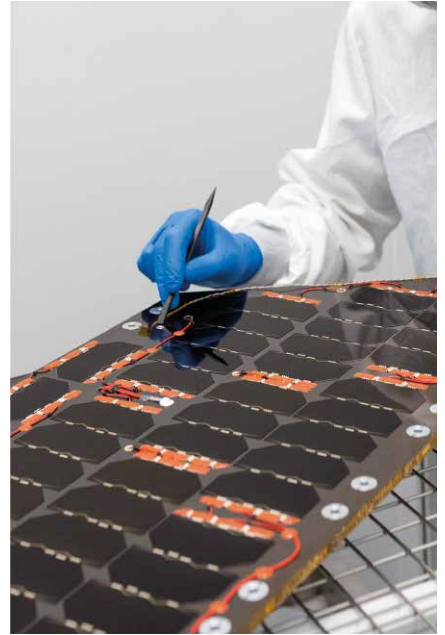

www.dhvtechnology.com

MAIN OFFICE

Tech Park of Andalusia
Severo Ochoa 13, 29590 Malaga - SPAIN
enquiry@dhvtechnology.com
+34 951 956 837

