



SOLUTIONS FOR AGRICULTURE AND BIOGAS

For guaranteed quality and optimum silage preservation





WHY CHOOSE CBS BETON?

30 years of experience in agriculture

In 1998, Henk Ciers started producing retaining walls under the name CBS Beton. The range was gradually expanded to include a wide selection of trench silo walls.

We have invested heavily in automation and employ some 200 motivated employees.

Quality – Certificates – Service

Since our founding in the late 1990s, production in Wielsbeke has evolved enormously, in both quality and organisation.

We constantly work to meet the demands of the marketplace in terms of **quality** – we have our own lab where samples are taken from production every day. We also have the necessary **certificates**. And we have the enthusiasm required to continue to earn them.

And last but not least ... CBS Beton also offers a **comprehensive logistics service**, from loading your truck to organising deliveries to the job site, with or without positioning from the truck. You ask, we produce and deliver.





Contents

- 2 Why choose CBS Beton?
- 4 - 5 Trench silo
- 6 Standardisation, design, production & quality control
- 7 Good compaction
- 8 - 9 External and intermediate walls
- 10 Conservation of maize, grass
Production of biogas
- 11 Agri L-Walls
- 12 Agri U-Walls
- 13 Agri T-Walls
- 14 Corner solutions for Agri walls
- 15 Trench silo blocks
- 16 - 17 Silo walls to be cast in
- 18 - 19 Turnkey trench silo
- 20 Storage of grain and tuber crops
- 21 Grain Ts
- 22 - 23 Round storage tanks for liquid manure and biogas
- 24 - 25 Lifting hooks
- 26 - 27 The Silage Safe silage cover system

TRENCH SILO

Silage preservation

get the most out of your trench silo



Safe storage and slopes up to 30°. This way, you get the most out of your silo.

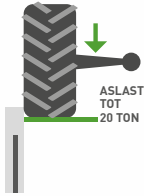

CBS Beton offers Agri walls up to **20 tonnes axle load**. Even the heaviest tractors and silage wagons can be driven safely alongside our Agri walls.



CBS Beton is the only company with all the necessary certificates for agricultural concrete products.

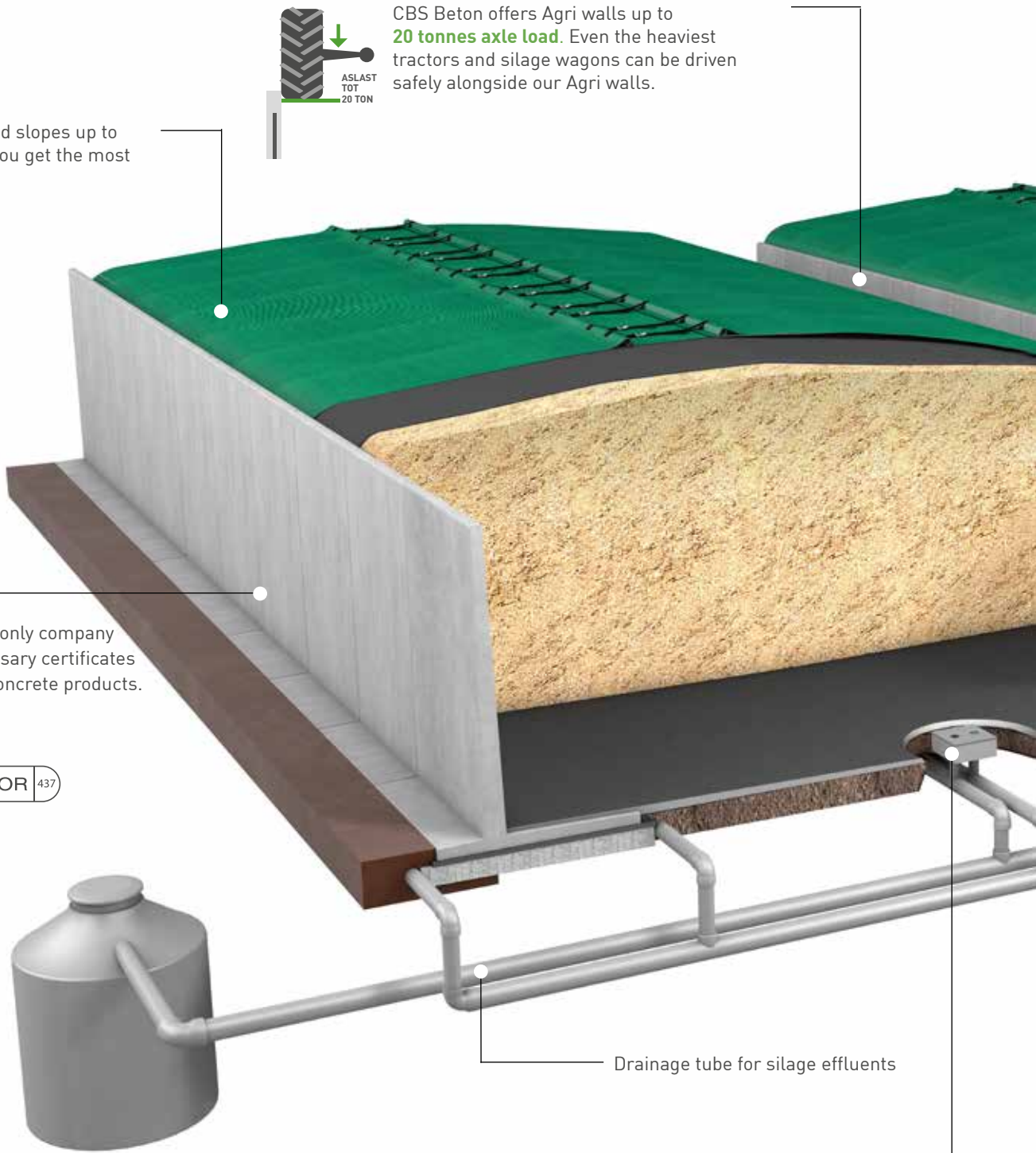

Storage tank for silage effluents.

Drainage tube for silage effluents

The drains are ideal for separating rainwater and silage effluents.

Silage Safe

The Silage Safe cover system guarantees optimum preservation of your silage, combined with unique juice drainage. Besides being back-saving and ergonomic, it is also very efficient.



A dry matter content of 35 % on average ensures better fodder and therefore more milk.

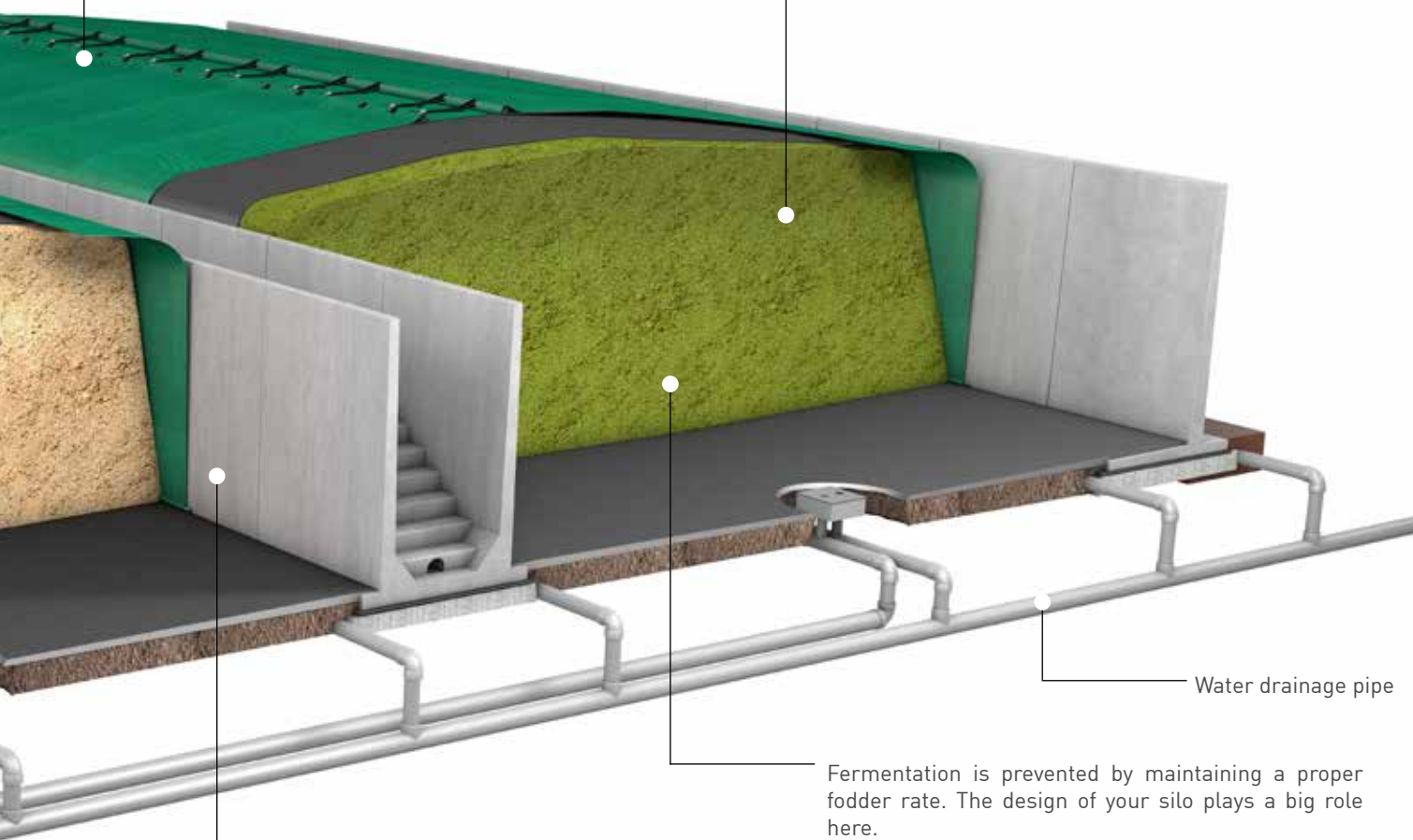

Maintain and check your trench silos at regular intervals.

Fermentation is prevented by maintaining a proper fodder rate. The design of your silo plays a big role here.

What to consider when buying a trench silo?

- Which kind of silage will I ensile?
- What storage capacity do I need and are there future expansion plans?
- What load should the walls be able to handle?
- Which cover system do I want to use?
- How can I separate rainwater and silage effluents?
- How should the trench silo be orientated?
- What certificates are required?

Standardisation, design, production & quality control

Did you know ...

CBS Beton is the **only manufacturer** to hold a **BENOR certificate** obtained for prefabricated agricultural concrete products in the wall and/or retaining wall elements category for silo and cellar walls. This certificate guarantees that all concrete elements are designed and produced to maximise their lifespan. Our walls also comply with all Belgian and European standards. CBS Beton has an in-house design and engineering office which allows us to develop an appropriate proposal to avoid surprises during the implementation of your project.

CBS Beton's concrete products are manufactured in accordance with **European concrete standard NBN EN 206: 2013 + A2: 2021** and **Belgian national supplement NBN B 15-001: 2018**.

Our retaining walls are designed in accordance with the applicable standards.

- NBN EN 1990: Eurocode 0 - Basis for structural design + national annex
- NBN EN 1991: Eurocode 1 - Loads on structures + national annexes
- NBN EN 1992: Eurocode 2 - Design and calculation of concrete structures + national annexes
- NBN EN 1997: Eurocode 7 - Geotechnical design + national annexes

Design principles

Concrete strength class: high-strength concrete C60/75
Environmental classes (NBN EN 206: 2013 + A2: 2021)

- XC4: corrosion by carbonation, concrete with reinforcement exposed to air and moisture, alternately wet and dry
- XD3: attack by chlorides such as de-icing salt, alternating wet and dry
- XS3: tidal, splash and spray zone
- XF4: frost, with or without de-icing salts: high water saturation with de-icing salts
- XA3: highly aggressive chemical environment according to table 2 of NBN EN 206: 2013 + A2: 2021

Environmental classes (NBN B 15-001:2018)

- EE4: frost and de-icing salts (presence of locally thawed deicing water)
- ES4: sea environment: tidal and splash zone
- EA3: highly aggressive chemical environment

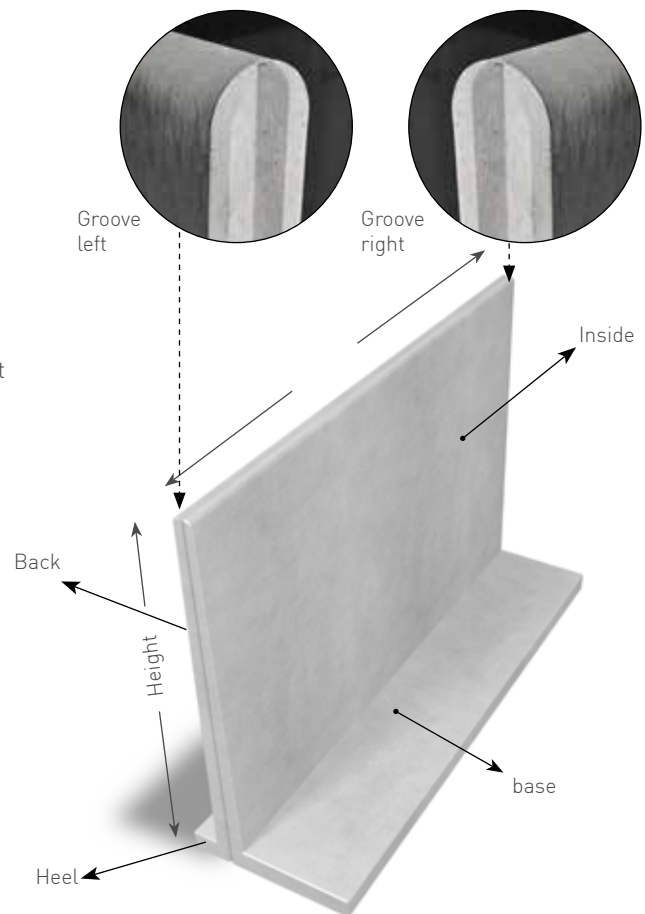

Good compaction

A high wheel pressure is vital for properly compacting your silage pit. The higher the axle load, the better the silage compaction. This applies to every pit: corn, grass or "lasagna". The higher the wheel pressure, the better the compaction.



An edge distance of 0 cm!

Our silo walls are designed so you can drive right up to the edge. This allows the entire width of the silo to be used to compact the silage. This is the best way to preserve your silage.

Axle load



The axle load is calculated by dividing the mass of the compactor by the number of axles (so usually by 2). At CBS Beton, all walls are calculated with an edge clearance of 0 cm so that you can drive over the full width of your silo. Here, CBS Beton meets the strictest standards. When choosing your new silo, it is very important to check both the axle load and the edge clearance.

The use of tandem and tridem combinations requires a special calculation. If you want to drive these machines to the edge, it is best to contact our engineering office.

That is why you choose CBS Beton

- ✓ CBS Beton's plants are certified to CE marking 2+. This means that the entire design and production chain is assessed by an externally recognised assessment body. As a result, all products are CE marked.
- ✓ All products are manufactured in C60/75 certified, high-strength concrete. This is the highest strength class on the market. They also comply with the highest chemical class XA3 (EA3).
- ✓ All visual surfaces are smooth-formed. The use of self-compacting concrete means they are also very dense and meet the highest visibility class.
- ✓ Our unique single-stage pouring system makes the wall-floor connections of the Agri walls watertight.
- ✓ Our product range includes walls with axle loads of up to 20 tonnes and an edge clearance of 0 cm.
- ✓ You will also find quality on the inside. All reinforcement is produced by our own steel company CCS-Steel.
- ✓ Our installation service guarantees fast and professional installation. Your silo can go into operation immediately after installation.
- ✓ The sealant service has the right solution for sealing your trench silo. Air and water are kept out. Our specialists will be happy to suggest a suitable, customised sealant system.



OUTER AND INTERMEDIATE WALLS



L-Walls

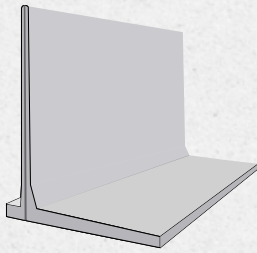

U-Walls

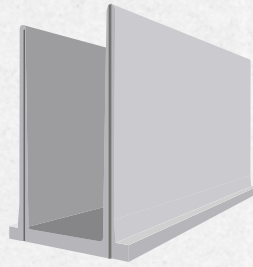

T-Walls

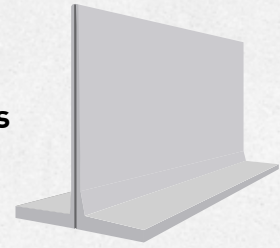

Axle loads on L outer walls

PRODUCT	FREESTANDING	WITH EARTH WALL
CLF10AM	7 tons	10 tons
CLF10A	10 tons	15 tons
CLAGRI	15 tons	20 tons
DLAGRI	20 tons	20 tons

Axle loads on intermediate walls

PRODUCT	DOUBLE-LOADED
CTAM	7 tons
CTA	10 tons
CTAGRI	15 tons
CUAGRI	15 tons
ETAGRI	20 tons

Axle loads on intermediate & outer walls

PRODUCT	DOUBLE-LOADED
CSAN	7 tons

Freestanding

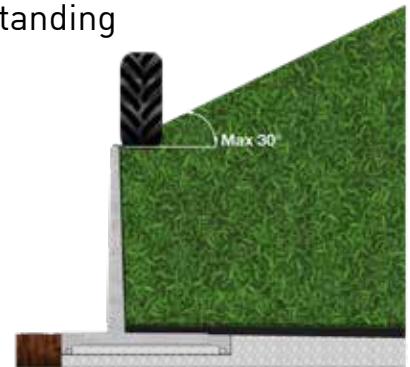

With earth



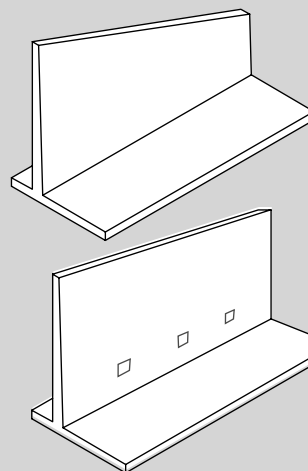

BEVELLED WALLS

On request or according to design, our walls can be bevelled. Customisation is not a problem.

WALLS WITH MAIZE BRACKETS

We can provide stainless steel maize brackets in the walls.

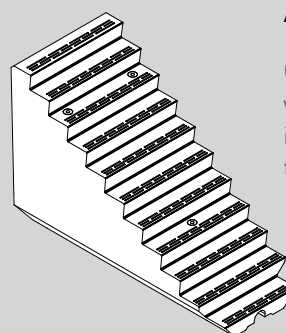

AGRI TRAP

Our U-walls can be fitted with stairs at the end. There is a recess for drainage at the bottom.

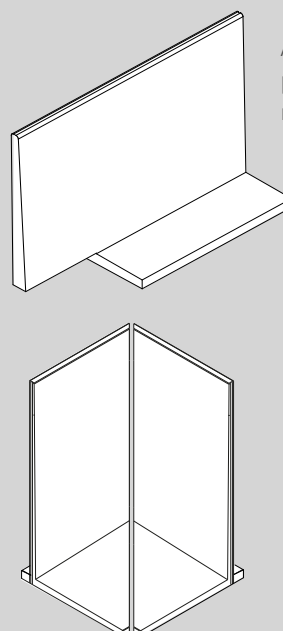

CORNERS

Any desired corner is possible. Overlapping or mitred corners are used.

CONSERVATION OF MAIZE, GRASS PRODUCTION OF BIOGAS



AGRI L-WALLS

STORAGE: MAIZE, GRASS - BIOGAS PRODUCTION

Completely smooth

- Measuring and fitting possible
- Length adjustment
- With bevel
- Modification for corner formation

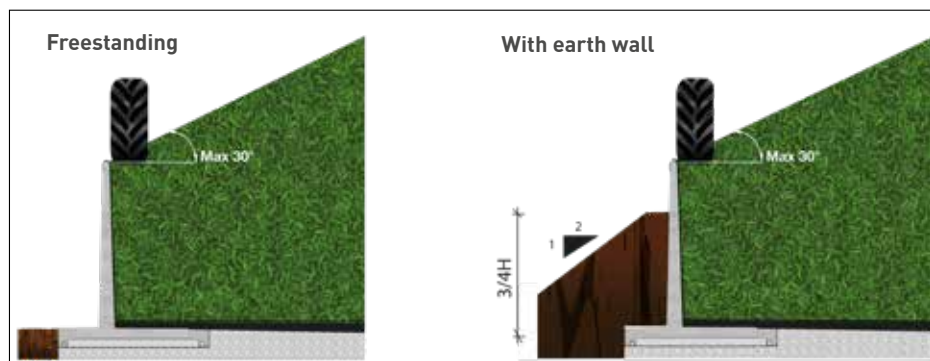

HEIGHT

D1

D2

D3

D4

BASE

rounded top edge for foil

right angle for silage removal

MODIFIED/ADDITIONAL ELEMENTS

left

right

With bevel

HL HR

Agri L-corner section

With bevel

2-piece corners

AGRI L-WALLS FREESTANDING 7 TONNE - 10 TONNE AXLE LOAD WITH EARTH WALL

	HEIGHT - CM	LENGTH CM	BASE CM	D1 CM	D2 CM	D3 CM	D4 CM	WEIGHT KG	LIFTING HOOKS	CONNECTION	CONCRETE QUALITY
CLF10AM 200x200	200	200	125	10.00	16.50	12.00	12.00	1757	2 x 2.5 T	groove - groove	C60/75
CLF10AM 250x200	250	200	150	10.00	20.50	14.00	14.00	2367	2 x 2.5 T	groove - groove	C60/75
CLF10AM 300x200	300	200	175	10.00	25.00	17.00	17.00	3165	2 x 5 T	groove - groove	C60/75

AGRI L-WALLS FREESTANDING 10 TONNE - 15 TONNE AXLE LOAD WITH EARTH WALL

	HEIGHT - CM	LENGTH CM	BASE CM	D1 CM	D2 CM	D3 CM	D4 CM	WEIGHT KG	LIFTING HOOKS	CONNECTION	CONCRETE QUALITY
CLF10A 200x200	200	200	140	10.00	16.50	12.00	12.00	1857	2 x 2.5 T	groove - groove	C60/75
CLF10A 250x200	250	200	175	10.00	20.50	12.00	14.00	2540	2 x 2.5 T	groove - groove	C60/75
CLF10A 300x200	300	200	210	10.00	25.00	12.00	17.00	3424	2 x 5 T	groove - groove	C60/75

AGRI L-WALLS FREESTANDING 15 TONNE - 20 TONNE AXLE LOAD WITH EARTH WALL

	HEIGHT - CM	LENGTH CM	BASE CM	D1 CM	D2 CM	D3 CM	D4 CM	WEIGHT KG	LIFTING HOOKS	CONNECTION	CONCRETE QUALITY
CLAGRI 139x500	139	500	105	12.00	15.00	14.00	15.00	3900	2 x 2.5 T	groove - groove	C60/75
CLAGRI 164x500	164	500	105	12.00	15.00	14.00	15.00	4380	2 x 2.5 T	groove - groove	C60/75
CLAGRI 189x500	189	500	135	12.00	16.00	14.00	15.00	5440	2 x 5 T	groove - groove	C60/75
CLAGRI 214x500	214	500	135	12.00	16.00	14.00	15.00	5900	2 x 5 T	groove - groove	C60/75
CLAGRI 264x400	264	400	180	12.00	20.00	14.00	15.00	6680	none	groove - groove	C60/75
CLAGRIP 316x250	316	250	200	12.00	22.00	15.00	17.00	5256	none	groove - groove	C60/75
DLAGRIP 423x200	423	200	250	12.00	30.00	22.00	24.00	7160	none	groove - groove	C60/75

AGRI L-WALLS FREESTANDING 20 TONNE AXLE LOAD

	HEIGHT - CM	LENGTH CM	BASE CM	D1 CM	D2 CM	D3 CM	D4 CM	WEIGHT KG	LIFTING HOOKS	CONNECTION	CONCRETE QUALITY
ELAGRIP 271x400	271	400	231	12.00	24.00	21.00	21.00	9138	none	groove - groove	C60/75
ELAGRIP 324x250	324	250	270	12.00	27.00	24.00	24.00	7325	none	groove - groove	C60/75
ELAGRIP 423x200	423	200	290	12.00	30.00	22.00	23.00	7150	none	groove - groove	C60/75

P At the bottom of the wall, greater concrete coverage on the reinforcement is provided for longer protection against acids = sacrificial layer.

AGRI U-WALLS

STORAGE: MAIZE, GRASS - BIOGAS PRODUCTION

Completely smooth

- Measuring and fitting possible
- Length adjustment
- With bevel
- 1 side enclosed as capped/end wall

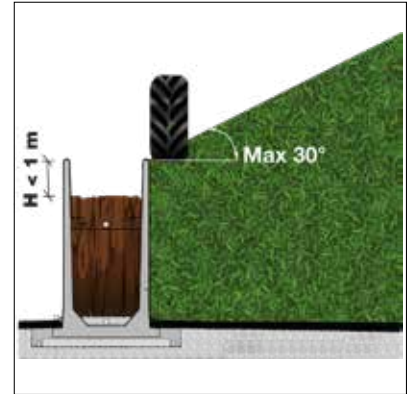



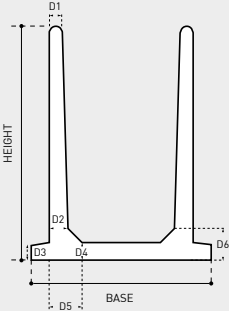

MODIFIED/ADDITIONAL ELEMENTS

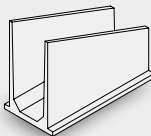

with bevel

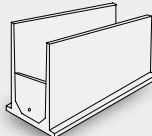

capped/end wall

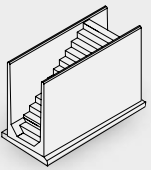

with stairs

AGRI U-WALLS 15 TONNE AXLE LOAD													
	HEIGHT CM	LENGTH CM	BASE CM	D1 CM	D2 CM	D3 CM	D4 CM	D5 CM	D6 CM	WEIGHT KG	LIFTING HOOKS KKA	CONNECTION	CONCRETE QUALITY
CUAGRIZ 214x400	214	400	170	10.00	15.00	14.00	15.00	30.00	35.00	7570	4 x 5 T	groove -	C60/75
CUAGRI ^{PZ} 264x400	264	400	190	10.00	15.00	14.00	18.00	40.00	48.00	9852	4 x 5 T	groove -	C60/75
CUAGRI ^{PZ} 316x400	316	400	191	10.00	16.50	16.00	20.00	41.50	50.00	11723	4 x 5 T	groove -	C60/75
CUAGRI ^{PZ} 316x250	316	250	191	10.00	17.10	15.00	18.00	25.30	26.80	7125	4 x 5 T	groove -	C60/75

P At the bottom of the wall, greater concrete coverage on the reinforcement is provided for longer protection against acids = sacrificial layer.



AGRI T-WALLS

STORAGE: MAIZE, GRASS - BIOGAS PRODUCTION

Completely smooth

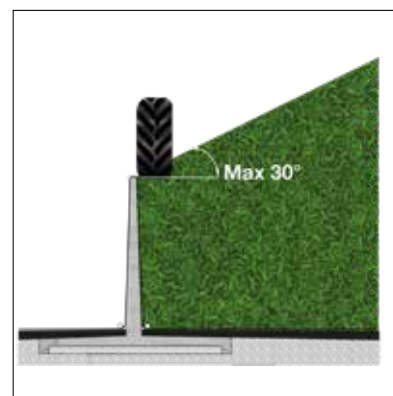

- Measuring and fitting possible
- Length adjustment
- With bevel
- Modification for corner formation

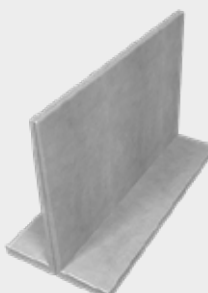

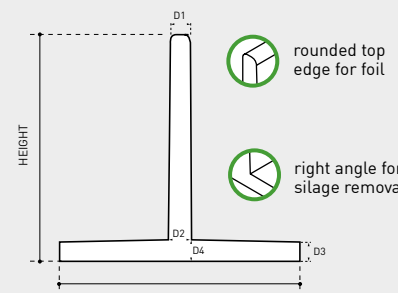

MODIFIED/ADDITIONAL ELEMENTS

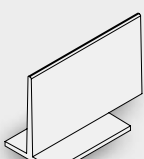

slide-on T (for corner)

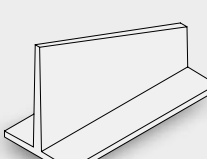

with bevel

AGRI T-WALLS 7 TONNE AXLE LOAD

	HEIGHT - CM	LENGTH CM	BASE CM	D1 CM	D2 CM	D3 CM	D4 CM	WEIGHT KG	LIFTING HOOKS	CONNECTION	CONCRETE QUALITY
CTAM 200x200	200	200	135	10.00	19.00	12.00	12.00	1874	4 x 2.5 T	groove - groove	C60/75
CTAM 250x200	250	200	160	10.00	23.00	12.00	14.00	2564	4 x 2.5 T	groove - groove	C60/75
CTAM 300x200	300	200	190	10.00	23.00	12.00	17.00	3421	4 x 2.5 T	groove - groove	C60/75

AGRI T-WALLS 10 TONNE AXLE LOAD

	HEIGHT - CM	LENGTH CM	BASE CM	D1 CM	D2 CM	D3 CM	D4 CM	WEIGHT KG	LIFTING HOOKS	CONNECTION	CONCRETE QUALITY
CTA 200x200	200	200	135	10.00	19.00	12.00	12.00	1874	4 x 2.5 T	groove - groove	C60/75
CTA 250x200	250	200	160	10.00	23.00	12.00	14.00	2564	4 x 2.5 T	groove - groove	C60/75
CTA 300x200	300	200	190	10.00	23.00	12.00	17.00	3421	4 x 2.5 T	groove - groove	C60/75

AGRI T-WALLS 15 TONNE AXLE LOAD

	HEIGHT - CM	LENGTH CM	BASE CM	D1 CM	D2 CM	D3 CM	D4 CM	WEIGHT KG	LIFTING HOOKS	CONNECTION	CONCRETE QUALITY
CTAGRI 139x500	139	500	135	12.00	15.00	14.00	15.00	4340	4 x 2.5 T	groove - groove	C60/75
CTAGRI 164x500	164	500	120	12.00	18.00	14.00	15.00	4980	4 x 2.5 T	groove - groove	C60/75
CTAGRI 214x500	214	500	160	12.00	18.00	14.00	15.00	6800	none	groove - groove	C60/75
CTAGRI 264x400	264	400	180	12.00	22.00	14.00	16.00	7000	none	groove - groove	C60/75
CTAGRIP 316x250	316	250	200	12.00	25.00	16.00	18.00	5580	none	groove - groove	C60/75
CTAGRI 422x200	422	200	240	12.00	30.00	22.00	23.00	7040	none	groove - groove	C60/75

AGRI T-WALLS 20 TONNE AXLE LOAD

	HEIGHT - CM	LENGTH CM	BASE CM	D1 CM	D2 CM	D3 CM	D4 CM	WEIGHT KG	LIFTING HOOKS	CONNECTION	CONCRETE QUALITY
ETAGRIP 324x250	324	250	250	12.00	24.50	17.50	24.50	6647	none	groove - groove	C60/75

P At the bottom of the wall, greater concrete coverage on the reinforcement is provided for longer protection against acids = sacrificial layer.

CORNER SOLUTIONS FOR AGRI WALLS

1) Corner elements for L-walls

	HEIGHT CM	LENGTH CM	BASE CM	KKA	WEIGHT KG
CLAGRIHL/HR 139x485	139	485	105	2 x 2.5 T	3528
CLAGRIHL/HR 164x485	164	485	105	2 x 2.5 T	3930
CLAGRIHL/HR 189x484	189	484	135	2 x 5 T	4725
CLAGRIHL/HR 214x484	214	484	135	2 x 5 T	5142
CLAGRIHL/HR 264x380	264	380	180	-	5261

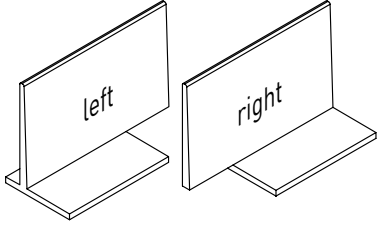

2) Corner elements for T-walls

	HEIGHT CM	LENGTH CM	BASE CM	KKA	WEIGHT KG
CTAGRIO 139x485	139	485	135	4 x 2.5 T	3962
CTAGRIO 164x485	164	485	120	4 x 2.5 T	4416
CTAGRIO 214x484	214	484	160	4 x 5 T	5718
CTAGRIO 264x380	264	380	180	-	5666

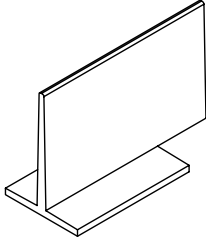

3) Two-part 90° corner (2 x 45°) for L-walls

	HEIGHT CM	LENGTH CM	BASE CM	WEIGHT KG
CLAGRI ^P HL 316x250	316	250	200	4664
CLAGRI ^P HR 316x250	316	250	200	4664

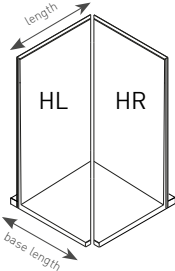

4) Two-part 90° corner (2 x 45°) + corner column for L- and T-walls

	HEIGHT CM	LENGTH CM	BASE CM	WEIGHT KG
DLAGRIHL 423x200	423	200	250	6142
DLAGRIHR 423x200	423	200	250	6142
CTAGRIPO 316x250	316	238	200	4946

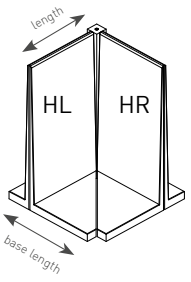

TRENCH SILO BLOCKS

STORAGE: MAIZE, GRASS

Completely smooth

- Measuring and fitting possible
- Length adjustment
- Corner solutions

Storing on an existing floor without additional earthwork is possible with our robust A-blocks. The groove system combined with their own high weight keeps the elements in place. Due to the 80 cm width at the bottom, the blocks do not shift during ensiling. The maximum pit height is 2 m.

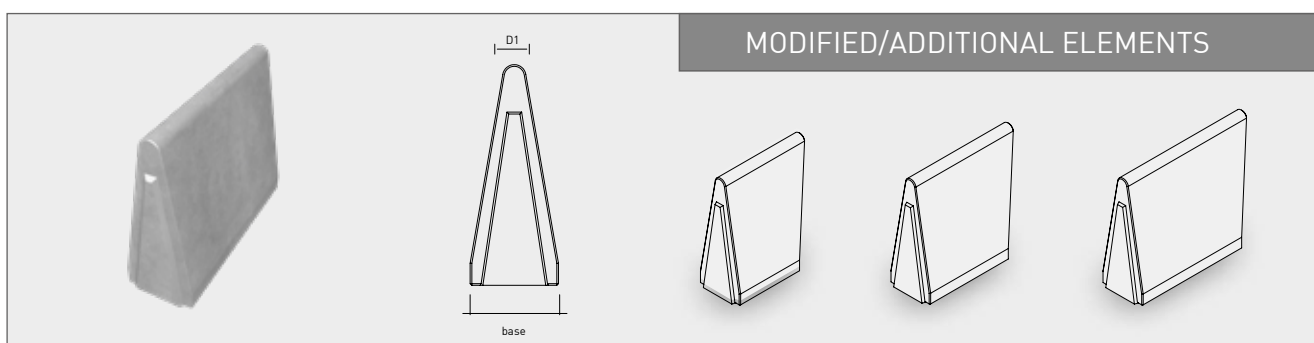

	HEIGHT CM	LENGTH CM	BASE CM	D1 CM	WEIGHT KG	LIFTING HOOKS MRD24	CONCRETE QUALITY
CAB 200x119	200	119	80	21.00	3011	1 x MRD24	C60/75
CAB 200x159	200	159	80	21.00	4027	2 x MRD24	C60/75
CAB 200x199	200	199	80	21.00	5044	2 x MRD24	C60/75
CAB 200x239	200	239	80	21.00	6060	2 x MRD24	C60/75



SILO WALLS TO BE CAST IN STORAGE OF MAIZE, GRASS, SOLID MANURE HEAP

1 side completely smooth-formed + 1 side smoothed

- Length adjustment
- Bevel

These walls are used to construct a trench silo or other storage area: the slabs are anchored by reinforcement bars via the openings at the bottom into the on-site poured bottom slab. The advantage of these elements is their tongue-and-groove connection and greater possibilities for customisation (length adjustment, chamfers).

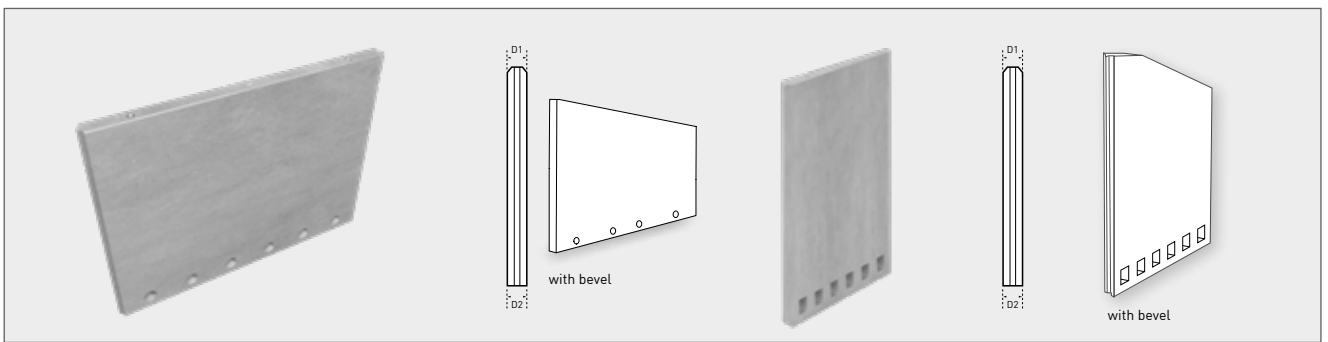

TRENCH SILO WALLS 7-TONNE AXLE LOAD DOUBLE-LOADED										
	TOTAL HEIGHT CM	USEFUL HEIGHT - CM	LENGTH CM	D1 CM	D2 CM	WEIGHT KG	LIFTING HOOKS KKA	CONNECTION	CONCRETE QUALITY	CSBLOK CM
CSAN 125x300	125	100	300	15	15	1360	2 x 2.5 T	tooth - groove	C60/75	22,5x30
CSAN 150x300	150	125	300	15	15	1600	2 x 2.5 T	tooth - groove	C60/75	22.5x30
CSAN 175x300	175	150	300	15	15	1900	2 x 2.5 T	tooth - groove	C60/75	22.5x30
CSAN 200x300	200	175	300	15	15	2160	2 x 2.5 T	tooth - groove	C60/75	22.5x30
CSAN 225x300	225	200	300	15	15	2480	2 x 2.5 T	tooth - groove	C60/75	22.5x30
CSAN 250x300	250	225	300	15	15	2755	2 x 2.5 T	tooth - groove	C60/75	22.5x30
CSAN 280x225	280	250	225	16	16	2380	2 x 2.5 T	tooth - groove	C60/75	22.5x30
CSAN 340x225	340	310	225	16	16	2900	2 x 2.5 T	tooth - groove	C60/75	22.5x30

PLAATSINGSVOORSCHRIFTEN						
H	d	H*	wachtwapening, per opening		a	L
			B	B		
125	25	100	70	2x60	1a14	125
150	25	125	70	2x60	1a14	125
175	25	150	70	2x60	1a14	125
200	25	175	80	2x65	1a16	135
225	25	200	80	2x65	1a16	135
250	25	225	80	2x65	1a16	135
280	30	250	100	2x75	1a16	155
340	40	300	100	2x80	1a16	165

* Nuttige hoogte



ACCESSORIES FOR TRENCH SILO WALLS: CS SET BLOCKS

- 1 - You have 2 options for securing panels:
A - cast base (to be provided by customer) + block and bolt
 OR
B - prefabricated levelling block + wooden wedges
- 2 - Iron for holes
- 3 - SIKAFLEX OR SILICONE jointing agent
 Silicone is a commonly used grout to seal the joints after wall installation.
 Alternatively, Sikaflex can be used; it seals even better and has a longer lifespan.

Order and place your adjustment blocks in advance to prepare your yard for installation!

Up to a height of 340 cm
 • H 22.5 x W 30 x L 45 cm



From a height of 340 cm
 • H 42 x W 30 x L 150 cm



SET BLOCKS

	HEIGHT CM	LENGTH CM	WIDTH CM	WEIGHT KG	LIFTING HOOKS KKA	CONCRETE QUALITY
CSBLOK 22.5x30	22.5	45	30	41	-	C60/75
CSBLOK 42x30	42	150	30	263	2 x 1.3 T	C60/75

TRENCH SILO WALLS 7-TONNE AXLE LOAD SINGLE-LOADED

	TOTAL HEIGHT CM	USEFUL HEIGHT - CM	LENGTH CM	D1 CM	D2 CM	WEIGHT KG	LIFTING HOOKS MRD24	CONNECTION	CONCRETE QUALITY	CSBLOK CM
CSA 445x200	445	400	200	25	25	5285	2 x MRD24	tooth - groove	C60/75	42x30
CSA 555x200	555	500	200	25	25	6680	2 x MRD24	tooth - groove	C60/75	42x30

TRENCH SILO WALLS 7-TONNE AXLE LOAD DOUBLE-LOADED

	TOTAL HEIGHT CM	USEFUL HEIGHT - CM	LENGTH CM	D1 CM	D2 CM	WEIGHT KG	LIFTING HOOKS MRD24	CONNECTION	CONCRETE QUALITY	CSBLOK CM
CSAD 445x200	445	400	200	25	25	5325	2 x MRD24	tooth - groove	C60/75	42x30
CSAD 555x200	555	500	200	25	25	6745	2 x MRD24	tooth - groove	C60/75	42x30

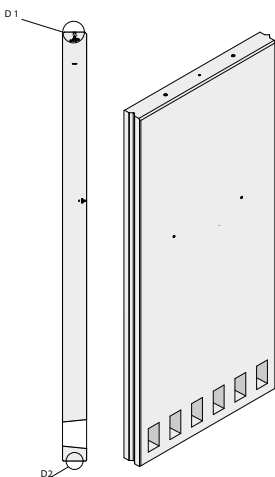

TURNKEY TRENCH SILO

CBS Beton does all the coordination for you.

1) Advice and design

A design is first prepared for the construction of complex trench silos.

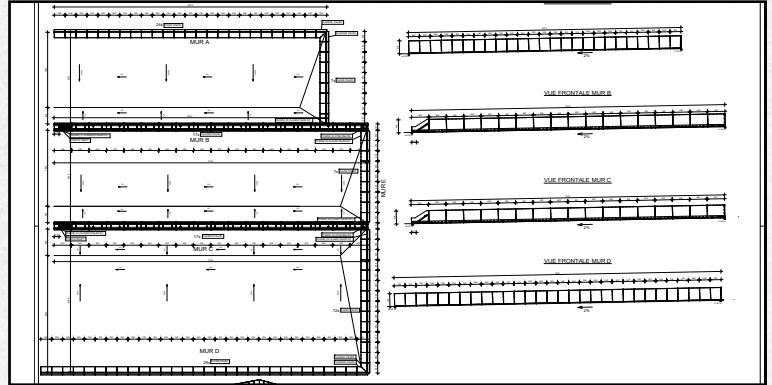

2) Foundation

The installation of silo walls requires a solid foundation with sufficient bearing capacity for the walls being installed. The builder is responsible for designing the foundation.



3) Placement

The walls are installed by CBS Beton's own professional installation service. We can install up to 200 lm per day.



4) Finish

Spacers are placed between the walls for subsequent sealing. For walls located side by side, we apply a Sikaflex joint sealant with a filler gun.



How do we go about sealing?

The sealing process uses spacers because the walls are not placed against each other.



- 1) Apply a dot of Sikaflex above and below the groove.
- 2) Place the spacer in the groove.
- 3) Apply duct tape along 1 side to fix the spacer in place.
- 4) Place the 2 concrete elements against each other.
- 5) Remove the duct tape up to the groove.
- 6) Seal the joint.

Groove-groove connection

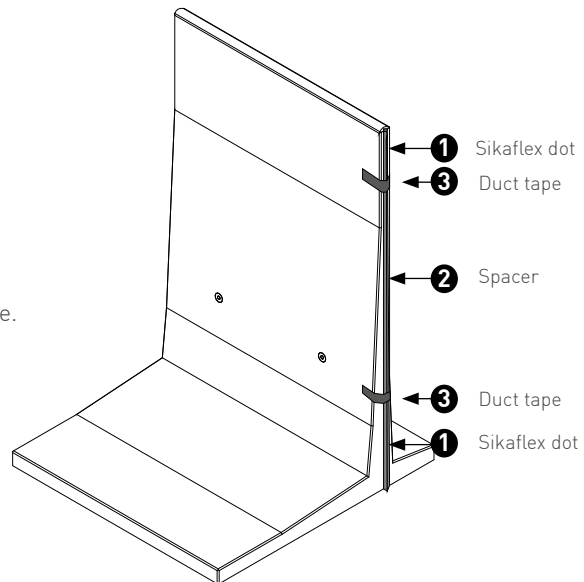
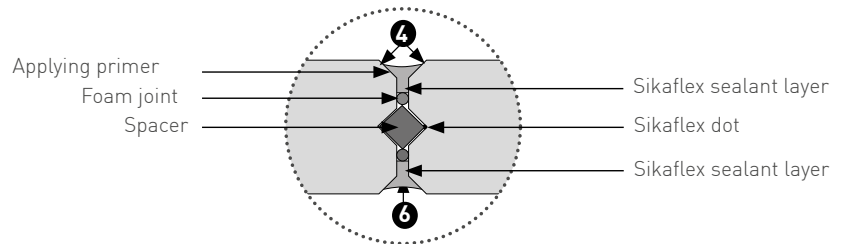

5) Pouring the floor

Asphalt and concrete need a good foundation to ensure the load-bearing capacity of the hardened result. Asphalt and concrete can be poured on almost any substrate provided a properly compacted foundation is laid.



2 STORAGE OF GRAIN AND TUBER CROPS



GRAIN T

STORING GRAIN, ONIONS AND POTATOES

COMPLETELY SMOOTH

The GRAIN T-wall is used for storing loose materials, e.g. grain and potatoes, and is suitable for use on an existing floor slab. The advantages: flexibility, high stability and easy to move with a forklift truck.

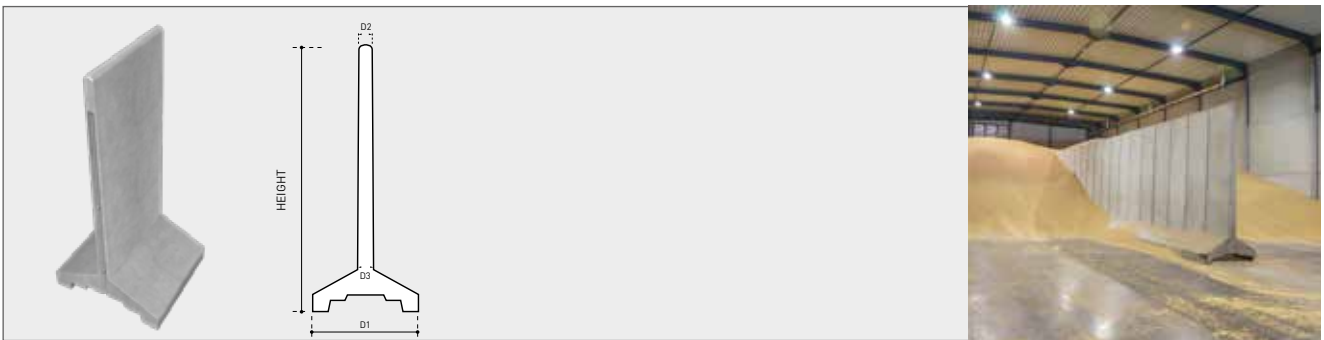

GRAIN Ts									
	HEIGHT CM	LENGTH CM	BASE CM	D1 CM	D2 CM	WEIGHT KG	LIFTING HOOKS RTA	CONNECTION	CONCRETE QUALITY
CTGRA 300x125	300	125	140	10	16	1990	1 x 1.25 T	tooth - groove	C60/75
CTGRA 400x100	400	100	200	10	24	2840	2 x 2.5 T	tooth - groove	C60/75

GRAIN Ts										
	HEIGHT CM	LENGTH CM	BASE CM	D1 CM	D2 CM	WEIGHT KG	LIFTING HOOKS		CONNECTION	CONCRETE QUALITY
							MRD24	MRD42		
CTGRA 500x100	500	100	240	24	50	6565	3 x MRD24	1 x MRD42	tooth - groove	C60/75
CTGRA 600x100	600	100	295	24	50	9520	3 x MRD24	1 x MRD42	tooth - groove	C60/75

MRD24 to raise the wall and MRD42 to straighten the wall.

Anti-slip mats for grain T-walls are only used at a height of 4 m

Non-slip rubber mats should be provided to prevent slipping under the T-walls only used at a height of 4 m, which are placed on a smooth concrete base. At heights of 5 and 6 m, fixing sealant is provided for chemical anchoring in the concrete floor.



ROUND STORAGE TANKS FOR LIQUID MANURE AND BIOGAS



Use and characteristics

Round storage tanks in precast concrete elements are used for manure storage, fermentation, as a water buffer, etc. The groove system, combined with tightened steel cables, ensures the liquid-tightness of your silo.

Our silos range in diameter from 5 to 45 m and in height from 3 to 8 m. We can make tanks up to 12,750 m³. Depending on the customer's requirements and wishes, CBS Beton advises and assists in the new construction, expansion or modification of storage facilities.

Placement

- Groundwork preparation by CBS Beton or by the customer
- Pouring the floor
- Application of a joint tape for watertight sealing between the floor and the ring beam
- Placing the elements on the hardened floor slab
- Application of special mortar between walls for a watertight finish
- Tightening the steel cables in a first stage
- Bringing the steel cables up to final tension in a second phase
- Casting of ring beam for connection between floor slab and precast elements

Advantages

- Flexible and quick installation
- Greater stability and impermeability to liquids by combining steel cable tensioning with the groove system



Why a silo roof?

- No rainwater in the silo and resistant to external weather influences
- No more odour nuisance and limited release of hazardous substances
- Tight assembly

SILO VOLUMES & INTERNAL DIAMETERS

*Panel width 1.56 m

H 3 M	H 4 M	H 5 M	H 6 M*	
VOLUME (m ³)				INTERNAL DIAMETER
76	101	126	150	5.57
89	119	148	178	6.06
104	138	173	207	6.55
119	159	199	239	7.04
136	182	227	272	7.53
154	206	257	309	8.02
173	231	289	347	8.50
194	258	323	387	8.99
215	287	359	430	9.48
238	317	396	475	9.96
261	348	435	522	10.45
286	381	476	571	10.93
312	416	519	622	11.42
339	452	564	676	11.90
367	489	611	732	12.39
396	528	659	790	12.87
427	568	710	850	13.36
458	610	762	913	13.84
491	654	816	978	14.33
524	698	872	1045	14.81
559	745	929	1114	15.29
595	792	989	1185	15.78
632	842	1050	1259	16.26
670	892	1114	1334	16.75
709	944	1179	1412	17.23
749	998	1245	1493	17.71
791	1053	1314	1575	18.20
833	1110	1385	1660	18.68
877	1168	1457	1746	19.16
922	1227	1532	1835	19.65
968	1289	1608	1927	20.13
1015	1351	1686	2020	20.61
1063	1415	1765	2116	21.09
1112	1481	1847	2214	21.58
1162	1548	1931	2314	22.06
1214	1616	2016	2416	22.54
1266	1686	2103	2520	23.03
1320	1757	2192	2627	23.51
1375	1830	2283	2736	23.99
1431	1905	2376	2847	24.48
1488	1980	2470	2960	24.96
1556	2058	2567	3076	25.44
1605	2136	2665	3193	25.92
1665	2217	2765	3313	26.41
1727	2298	2867	3435	26.89
1789	2382	2970	3560	27.35
1852	2466	3076	3686	27.85
1918	2553	3183	3815	28.34
1984	2640	3293	3964	28.82
2051	2729	3404	4079	29.30
2119	2820	3517	4215	29.79
2188	2912	3632	4352	30.27
2258	3006	3748	4492	30.75

*Panel width 2.40 m

H 6 M*		H 7 M		H 8 M	
VOLUME (m ³)	INTERNAL DIAMETER	VOLUME (m ³)	INTERNAL DIAMETER	VOLUME (m ³)	INTERNAL DIAMETER
387	9.06	424	8.78	484	8.78
455	9.83	492	9.46	562	9.46
528	10.58	565	10.14	645	10.14
606	11.34	643	10.81	735	10.81
689	12.09	726	11.49	830	11.49
778	12.85	814	12.17	930	12.17
872	13.60	390	12.84	1037	12.84
972	14.36	432	13.52	1149	13.52
1077	15.12	476	14.20	1267	14.20
1188	15.88	1216	14.87	1390	14.87
1303	16.63	1329	15.55	1519	15.55
1425	17.39	1447	16.22	1654	16.22
1551	18.14	1571	16.90	1795	16.90
1683	18.90	1699	17.58	1941	17.58
1820	19.65	1832	18.25	2093	18.25
1963	20.41	1969	18.93	2250	18.93
2112	21.17	2112	19.60	2414	19.60
2264	21.92	2260	20.28	2583	20.28
2422	22.67	2413	20.95	2758	20.95
2589	23.44	2571	21.62	2938	21.62
2758	24.19	2734	22.30	3124	22.30
2934	24.95	2902	22.97	3316	22.97
3113	25.70	3075	23.65	3514	23.65
3299	26.46	3343	24.66	3820	24.66
3492	27.22	3528	25.33	4032	25.33
3687	27.97	3719	26.01	4250	26.01
3890	28.73	3914	26.68	4473	26.68
4095	29.48	4114	27.36	4702	27.36
4309	30.24	4320	28.03	4937	28.03
4529	31.00	4530	28.70	5177	28.70
4750	31.75	4745	29.38	5423	29.38
4981	32.51	4966	30.05	5675	30.05
5213	33.26	5191	30.73	5932	30.73
5454	34.02	5421	31.40	6195	31.40
5700	34.78	5656	32.07	6464	32.07
5949	35.53	5897	32.75	6739	32.75
6206	36.29	6142	33.42	7019	33.42
6465	37.04	6392	34.10	7305	34.10
6733	37.80	6647	34.77	7596	34.77
7007	38.56	6907	35.44	7894	35.44
		7173	36.12	8197	36.12
		7442	36.79	8505	36.79
		7718	37.47	8820	37.47
		7998	38.14	9140	38.14
		8283	38.81	9466	38.81
		8573	39.49	9797	39.49
		8868	40.16	10135	40.16
		9168	40.84	10478	40.84
		9473	41.51	10825	41.51
		9782	42.18	11179	42.18
		10097	42.85	11539	42.85
		10417	43.53	11905	43.53
		10742	44.20	12276	44.20
		11063	43.53	12635	43.53
		11397	44.20	13017	44.20

TYPES OF LIFTING HOOKS

See technical sheet for lifting hooks needed for different types of walls.

- Ball head anchors (1) = KKA
- Ring transport anchors (2) = RTA
- Screw anchors = MRD24 - MRD42 (3)



4 THE SILAGE SAFE SILAGE COVER SYSTEM



Silage Safe

The innovative Silage Safe cover system allows you to move your silage in and out in a simple and labour-saving way.

Covering and opening your silage is often a physically demanding and time-consuming job. The method of covering also affects the quality of the silage.

Covering your silage airtight in an efficient way is therefore very important. The Silage Safe system allows you to cover your silage accurately and with minimal physical effort before rain arrives.



Silage Safe user manual



1

Do the parts not match the packing slip or do you have questions about the installation? Please contact CBS Beton.



2

Split the material into 2 groups. Group 1: half of the tarpaulins, PVC and steel tubes and all tensioning straps. This is for the left silo wall, seen from the pit entrance. Group 2: the other half of the tarpaulins, PVC and steel tubes and all buckles. This is for the right silo wall, seen from the pit entrance.



3

Start with group 1: lay a tarpaulin with the openings up and put the PVC pipe in the bottom hem, with the sleeve on the right.



4

Put the steel tube in the right hem; estimate the pit height. Put the tension straps around the tube at the openings. Do this for all the tarpaulins in group 1.



5

Lay a Group 2 tarpaulin with the openings facing up. Put the PVC pipe in the bottom hem, with the sleeve on the left.



6

Put the steel tube in the right hem and place the buckles at the openings. Do this for all the tarpaulins in group 2.



7

Lay the tarpaulins from group 1 over the left wall (seen from pit entrance), with the sleeve facing forward. Slide the tubes together. Always make sure that the rear tarpaulin overlaps the tarpaulin facing it. Do the same on the right side with the tarpaulins from group 2.



8

Lay the plastic over the walls (see over). Provide 10-20 cm clearance on the floor.



9

You can now ensile. Do this as round as possible for optimal tensile stress, with no room for oxygen.



10

Pull the plastic and then the tarpaulins over the pit. Connect all the tension straps with the buckles and pull the tarpaulins together.



11

Use the stainless steel tensioner: place the base of the tensioner behind the steel tube where the tensioning belt is attached. Pass the belt through the opening of the tensioner. Pull the tensioner towards you and repeat. Do this for all belts. Re-tension 1 and 3 weeks after ensiling to compensate for silage compaction.



12

Connect the 2 red PVC pipes to the grey PVC pipes at the pit entrance as marking and for rainwater drainage.



CBS Beton NV

Hooimeersstraat 8, 8710 Wielsbeke, Belgium.

Tel: + 32 56 61 75 37 - Fax: + 32 56 61 75 39 - info@cbs-beton.com - www.cbs-beton.com

We would like to point out that the information and notes in this technical catalogue do not constitute a complete and conclusive description. Rather, they are intended to supplement the generally recognised rules of building technology that the expert user must observe, and to explain the installation and use of our products. Further, we would like to point out that our products should only be used and installed by competent persons and that special attention should be paid to the proper handling and storage of our goods. We are always happy to assist you with the necessary advice and tips.