

# Extra Equipment

### LED Lights

LED Lights are available for all of our Sub-Tillers



### Warning Boards

Warning boards are available for safer transport.



### Front Disc

The machines can be fitted with front discs in line with the subsoiling tines to reduce surface soil disturbance. Only factory mounted option.



### Air Brakes

Air braking systems are available for all trailed Sub-Tillers as a factory fit option.



### Hydraulic Brakes

Hydraulic braking systems are available for all trailed Sub-Tillers as a factory fit option.



### Multi-Seeder

All Sub-Tillers can be fitted with a mounting kit suitable for the Multi-Seeder to save time by combining cultivation with the seeding of crops like OSR and cover crops.



### Ladder and Platform

Ladders and platforms are available to allow easy access to seeding units mounted to the machine.



### Easy-Draft Kit

The Low-Disturbance point has a shallower wing angle and a shorter tungsten tipped nose that opens the soil to create drainage without disturbing the whole soil profile.



## Sub-Tiller Combi

Sub-Tiller Combi is intended to function as a front tool / tool carrier for maize seed drills. It loosens the soil down to 40 cm. depth in front of each crop row.

There are various possibilities for the composition of the machine.



# Till-seeding with Sub-Tiller

A HE-VA Multi-Seeder allows the possibility of creating optimal growing conditions for rapeseed or aftercrops, such as mustard or fodder radish.



Seeding alongside soil loosening breaks up plough pans or other structural damage so that the roots of the plants have free access to grow/develop into the deeper soil layers.

This allows the plants' tap roots to draw nutrients and, in dry periods, water from deeper soil layers. Both rape and slug poison attachments are available for the Sub-Tiller, with options for band seeding, 1-row disc drill seeding after the roller and 2-row disc drill seeding after the roller. The snail poison is laid out in bands after either the roller or the depth wheel.

## Technical Specifications

### Three-Point Mounted



2.00 - 5.00 m



2.00 - 4.00 m



815 - 3,690 kg



60 - 360 hp



2 - 9 pcs.

Working Width, m	Type	Transport Width, m	Number of Tines	Power Req., hp	Square Tube Roller Weight, kg		V-Profile Roller (Ø600) Weight, kg		Star Roller Weight, kg	
					Quick-Push	Hydr.Auto.	Quick-Push	Hydr.Auto.	Quick-Push	Hydr.Auto.
2.00	Rigid	2.00	2 - 3	60 - 120	815 - 900	885 - 1,005	1,165 - 1,250	1,235 - 1,355	1,255 - 1,340	1,325 - 1,445
2.50	Rigid	2.50	2 - 3	60 - 120	900 - 985	970 - 1,090	1,415 - 1,500	1,485 - 1,605	1,470 - 1,555	2,055 - 1,660
3.00	Rigid	3.00	2 - 5	60 - 200	975 - 1,230	1,050 - 1,410	1,595 - 1,850	1,665 - 2,025	1,685 - 1,940	1,760 - 2,120
3.50	Rigid	3.50	5 - 7	140 - 280	1,310 - 1,480	1,490 - 1,720	2,030 - 2,200	2,210 - 2,440	2,150 - 2,320	2,330 - 2,560
4.00	Rigid	4.00	7	200 - 280	1,560	1,640	2,380	2,620	2,530	2,610
4.00	Hydr.	2.43	7	200 - 280	1,910	1,990	2,730	2,970	2,880	2,960
5.00	Hydr.	2.43	9	260 - 360	2,240	2,390	3,260	3,690	3,470	3,620

### Trailed



4.00 - 7.00 m



2.43 m



5,200 - 7,380 kg



220 - 600 hp



7 - 13 pcs.

Working Width, m	Type	Transport Width, m	Number of Tines	Power Req., hp	V-Profile Roller (Ø600) Weight, kg		V-Profile Roller (Ø700) Weight, kg	
					Quick-Push	Hydr.Auto.	Quick-Push	Hydr.Auto.
4.00	Hydr.	2.43	7	220 - 320	5,200	5,200	5,600	6,000
5.00	Hydr.	2.43	9	260 - 360	5,700	5,860	5,900	6,060
6.00	Hydr.	2.43	11	300 - 500	6,200	6,400	6,500	6,700
7.00	Hydr.	2.43	13	400 - 600	6,800	7,030	7,150	7,380



Tel.: +45 97 72 42 88  
E-mail: info@he-va.com

Web: www.he-va.com

N.A. Christensensvej 34  
DK-7900 Nykøbing Mors

Your HE-VA dealer



HE-VA reserves the right to make design and construction changes without notice



# Sub-Tiller

Efficient loosening of the soil without mixing



# Remove compaction, aerate and create drainage with the Sub-Tiller

The HE-VA Sub-Tiller has several frame options ranging from 2.50 to 4.00 m rigid, and 4.00 to 7.00 m folding models. Three-point mounted models are available from 2.00 to 5.00 m, and trailed models from 4.00 to 7.00 m. These are all available with a number of different leg options to create the correct specification for any individual farm.

Based on a traditional V formation design, HE-VA Sub-Tillers are built for strength and longevity. Each model incorporates hydraulic depth adjustment as well as a host of other features that makes them an operator's favourite.

## Stone Protection

### Quick-Push Stone Protection

The unique Quick-Push stone protection consists of a shearbolt with 8 predetermined breaking points.

When the legs brake back, the operator simply removes the holding pin, hammers another segment of the shearbolt through, and then returns the holding pin to its original position.

This removes the need to carry a supply of shearbolts while using the machine and ensures a minimum loss of time.

### Hydraulic Auto Reset Stone Protection

All models are available with hydraulic auto reset for extremely stony conditions.

An individual hydraulic ram on each leg which is connected to a gas accumulator allows the leg to break back and reset if it comes into contact with an unmovable object.

As the legs on a subsoiler are adjusted deeper, the leverage on the hydraulic reset ram increases and so a pressure gauge is used to allow the operator to set the force required for the leg to break back.

## Tine Design

### Low draft and quick assembly are key!

The V-shape of the Sub-Tiller combined with the angle of the points minimises draft and maximises effectiveness.

A standard Sub-Tiller has 200 mm wing share points mounted, but several other sizes are available for different applications.



The points are mounted with a single bolt, making them quick to replace and keeping down time to a minimum and effectiveness at its highest.



## Versatile Cultivation

Having manufactured Sub-Tillers, Discs and Combination Cultivators for over a decade, HE-VA have brought all their knowledge and experience together in the latest models of subsoilers.

Launched as a 3,00 m mounted machine in 2004, the range now includes trailed and larger hydraulic folding machines for use with up to 600 horsepower tractors. The HE-VA Sub-Tiller is designed with the operator in mind with all machine adjustments done from the tractor seat.



## Low Disturbance

The 15 mm low disturbance tine and tungsten tipped LD point are also the product of many years development. Whilst many customers are moving towards reduced tillage systems they appreciate that drainage is key to crop development, allowing timely field operations and preventing the relentless progress of grass weeds such as blackgrass. The low disturbance tine and point that HE-VA has developed allows deep soil loosening whilst minimising surface disturbance and preventing mixing of the soil profile.

The thinner legs are made from stronger Hardox 500 steel and can be interchanged with the standard Sub-Tiller tines as necessary. However it is the point that really makes the difference. The LD point has a shallower wing angle and shorter tungsten tipped nose that opens the soil to create drainage without disturbing the whole soil profile.

### Points

Whilst the 200 mm standard point is applicable for most tasks, a narrower 120mm version is available as well as a 350mm point. A simple change of point size will allow the Sub-Tiller to fit different soil types and varying working depths.



## Hydraulically Folded Sub-Tiller



### Extra productivity and mobility

For use with higher horsepower tractors on larger farm enterprises, the hydraulic folding Sub-Tillers from HE-VA are designed to tackle the toughest of challenges.

With 7, 9, 11 and 13 tine models available offering 4, 5, 6 and 7 metre working widths respectively, these machines combine outstanding performance and mobility to deliver substantial productivity benefits.

Each of the models split folds, folding down to a transport width of 2.43 m.

Mounted folding models have a 450 hp rated frame.

## Trailed Sub-Tiller



Trailed Sub-Tillers are rated to work with higher horsepower tractors up to 600 hp.

They offer the option of both Quick-Push shearbolt or automatic hydraulic reset stone protection.

Full lighting kits and low disturbance leg and points are available as an option on all mounted and trailed folding Sub-Tillers.

## Roller Types

The Sub-Tiller uses three different roller types. The V-Profile Roller - where each section of the roller turns as one ensuring the machine can continue to work in very wet sticky conditions. Each ring section is also castellated ensuring the roller turns in light soils and the aggressive rib and shoulder profile combines with the 145mm spacing to leave an excellent consolidated weatherproof finish. Individually mounted sprung steel scrapers prevent soil build up between the rings and keep the machine running in the wet.

The Square Tube Roller for use in lighter soil types to allow the surface to be loose and increase drainage to the lower soil profile.

The Star Roller increases drainage, consolidates the soil and leaves it loose.



V-profile roller  
Ø600-Ø700 mm

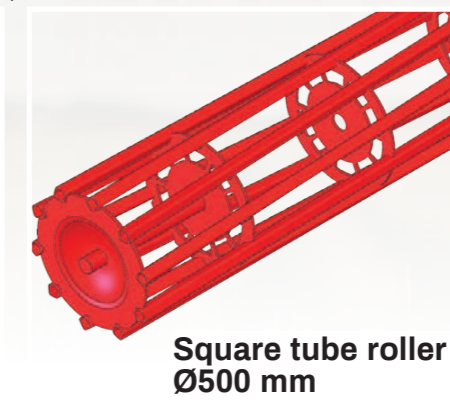

Square tube roller  
Ø500 mm



Star roller  
Ø450/500 mm