

EUROMARK
ELEVAGE



*Quality at
daily*

our **COMPACT
EMBLEMATIC
STRAW BLOWER
GETS A MAKEOVER**

More compact, more powerful, more robust

TX27HD

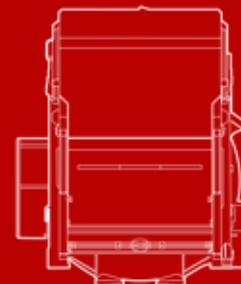
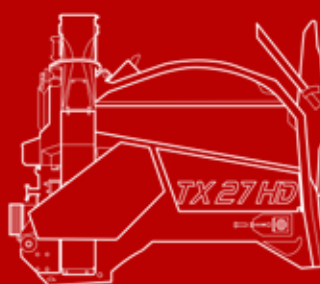

POWERDRIVE SYSTEM DRIVE

The **POWERDRIVE** allows independent operation of the turbine, unraveller and scraper floor. The hydraulically disengageable belt drive system for the shredder greatly reduces the power required at start-up and considerably reduces the risk of blockages.

The hydraulic belt tensioner allows the shredder to be engaged and disengaged at will from the electric control box in the cab. The system makes it possible to interrupt the flow of forage at any time at the touch of a button.

Heavy-duty quad-belt assembly for unrivalled longevity and power transmission. Energy-saving system thanks to new, improved hydraulic assembly.



SILENCE



FLEXIBILITY



POWER



*ESP and UESP models

MODELS:

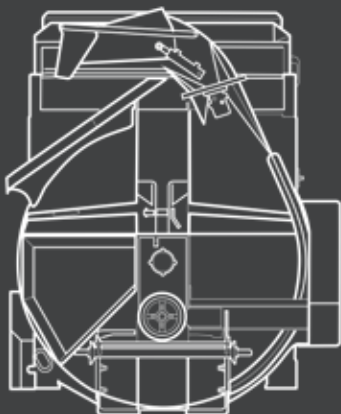

- **TX27HDEF** : Trailed / side chute / hydraulic shredder
- **TX27HDESP** : Trailed / side chute/ Shredder S.D.E. + **POWERDRIVE**
- **TX27HDSPEF** : Semi-trailed / side chute / hydraulic SHREDDER
- **TX27HDSPESP** : Semi-trailed / side chute / Shredder S.D.E. + **POWERDRIVE**
- **TX27HDSPUEF** : Semi-trailed / POLYFLOW chute / hydraulic shredder
- **TX27HDSPUESP** : Semi-trailed / POLYFLOW chute / Shredder S.D.E. + **POWERDRIVE**
- **TX27HDUEF** : Trailed / POLYFLOW chute / hydraulic shredder
- **TX27HDUESP** : Trailed / POLYFLOW chute / Shredder S.D.E. + **POWERDRIVE**

HIGHLIGHTS

EUROMARK DESIGN

MONOCOQUE BODY



- Fully mechanically welded and encircled by two tubular hoops:
→ Ultra-rigid
- Removable bottom and double bottom :
→ Easy replacement
→ Maximum machine life

DOUBLE-FLOW TURBINE



- Bolt-on **TWIN 8-blade** double-flow turbine
- Even mulching over long distances :
→ Fast, even distribution
- Low-profile turbine with reworked chamber
→ **Improved feed and ventilation**

HIGH-STRENGTH MOVING FLOOR



- **Ø 12 Grade 80** marine chain (**rupture à 18 Tonnes**)
- **HARDOX** nuts (abrasion-resistant steel)
→ Exceptional strength and durability
- Stainless steel wear angles, **INOX 3 mm thick**, installed under the entire length
- Shafts guided on roller bearings with grease fittings

MECHANICAL SHREDDER ALL FODDERS



- Démêleur **S.D.E.** all forage detangler with 40 cutting sections (80 optional)
- Can be untangled thanks to Powerdrive → Highly efficient for untangling and distribution of all types of forage (such as hay, wrapped grass, silage, short stalks, etc.)

HIGHLIGHTS

EUROMARK DESIGN



CHUTES

LATERAL:

- Mulching up to 24 meters*
- Movable cap on kinematics:
 - Facilitates distribution close to the tractor
 - Increases precision and power for long-distance mulching

ROTATING 320° POLYFLOW

- Paillage jusqu'à 18 mètres* (à droite)
- S'adapte aux différentes configurations de bâtiment → Polyvalence totale
- Toboggan de distribution à droite

*selon la qualité de la paille



HYDRAULIC DOOR

- Grande longueur avec vérins intégrés :
 - Facilite la coupe des filets / ficelles pour les balles rondes
 - Améliore le chargement des balles carrées allant jusqu'à 2m70 de longueur
- **Tube de retenue rabattable sur pivot avec verrouillage rapide :**
 - Mise en place du tube en un seul mouvement
 - Plus aucun obstacle sur le trajet des balles lors des phases de chargement



ELECTRIC CONTROLS

- Boîtier de commande intuitif avec ergonomie améliorée
 - toutes les fonctions essentielles sont à portée de main
- Boîtier totalement filaire
- Gestion de la vitesse du fond mouvant par potentiomètre de 0 à 10
- Commande électrique déportée à deux fonctions de série

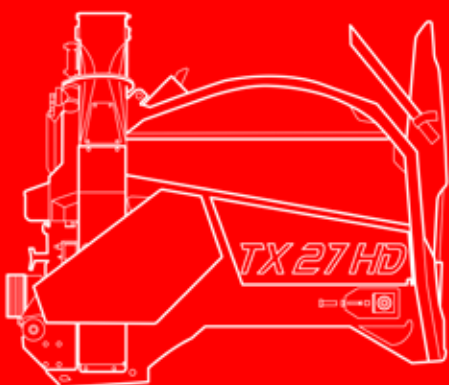

VARIOUS

- Two-speed gearbox
- Removable stainless steel housing
- Double bottom emptying trap
- Very low overhang
- Ultra-integrated hose routing
- Machine centre of gravity as close as possible to the hitch
- Adjustable towing jaws with 2 positions (long or short)
- **Powerdrive** clutch indicator rod
- Removable universal joint protection bowl



TX27HD

Even more powerful, even more robust and even more compact, the **TX27HD** continues the success story of its predecessors of more than 30 years (TX2701, TX2703, TX27HD). The **TX27HD** embodies the modernity, know-how and experience accumulated by Euromark over the years.

With a useful capacity of **2.5m³**, available in trailed or semi-trailed versions, with a side chute or a rotating chute, it offers a choice between a hydraulic shredder for straw or a mechanical shredder **S.D.E. PowerDrive** disengageable adapted to all types of forage.

Designed for all bale sizes, it accepts square bales up to 2.70m long and up to 120x120 cm in size, as well as round bales up to 2m in diameter.



* Non-contractual photos

STANDARD EQUIPMENTS

The EUROMARK **TX27HD** is available in a range of versions to meet all user needs and building configurations.

Trailed or semi-trailed model

SIDE CHUTE or **CENTRAL POLYFLOW CHUTE**

HYDRAULIC SHREDDER or **MECHANICAL SHREDDER S.D.E.**
all forage (40 sections / shredder)

- Double-flow turbine with 8 borged TWIN blades
- Removable stainless steel casing for direct access to the turbine
- Ergonomic wired electric controls with joystick
- Two-speed gearbox
- Extended hydraulic box (1200kg capacity)
- Cardan shaft with freewheel and friction safety device
- High resistance belt - Ø12 Grade 80 marine chain
- Hardox nuts
- 3mm stainless steel chain wear plates
- Belt shafts on roller bearings with grease nipple
- Cleanliness trap door
- Clutch indicator rod
- Quick-locking retaining tube
- Remote two-function control box (door + belt)

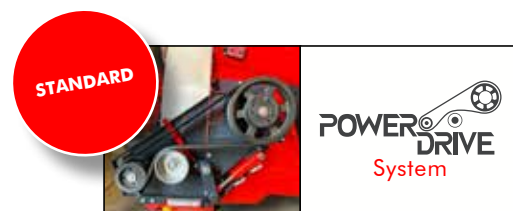

(*) S.D.E. : Wrapping Distribution System



SIDE CHUTE VERSION

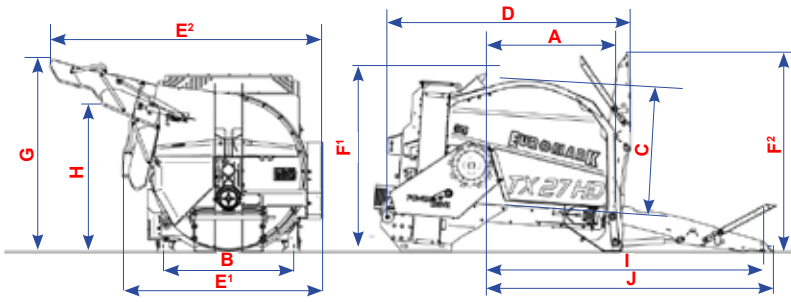

POLYFLOW VERSION

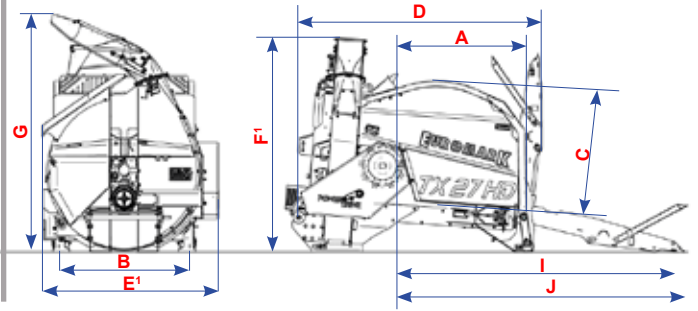

FEATURES

	TX27HD SIDE		TX27HD POLYFLOW	
	TRAILED	SEMI-TRAILED	TRAILED	SEMI-TRAILED
MULCHING DISTANCE				
Depending on the straw quality	SIDE CHUTE (ESP) : up to 24 m		CENTRAL POLYFLOW CHUTE (UESP) : up to 18 m*	
CAPACITY BEHIND THE SHREDDER (m³)	2.5			
DIMENSIONS INSIDE THE BOX				
A	1.4			
B	1.36			
C	1.32			
OVERALL DIMENSIONS				
D	2.55	3.44	2.55	3.44
E¹ / E²	2.10 / 2.85	2.15 / 2.90	1.85	2.07
F¹ / F²	1.86 / 2.07	2.05 / 2.53	2.24	2.39 / 2.53
OPEN MACHINE DIMENSIONS				
G	2.01	2.16	2.48	2.63
H	1.53	1.70	-	-
I	2.90	3	2.90	3
J	3	3.14	3	3.14
WEIGHT (KG)	1560* / 1630	1860* / 1930	1580* / 1650	1880* / 1950
TIRES	-	10/75x15 5 holes	-	10/75x15 5 holes
AXLE	-	50mm	-	50mm

STANDARD MACHINES



We share the
same passion.
Join us!

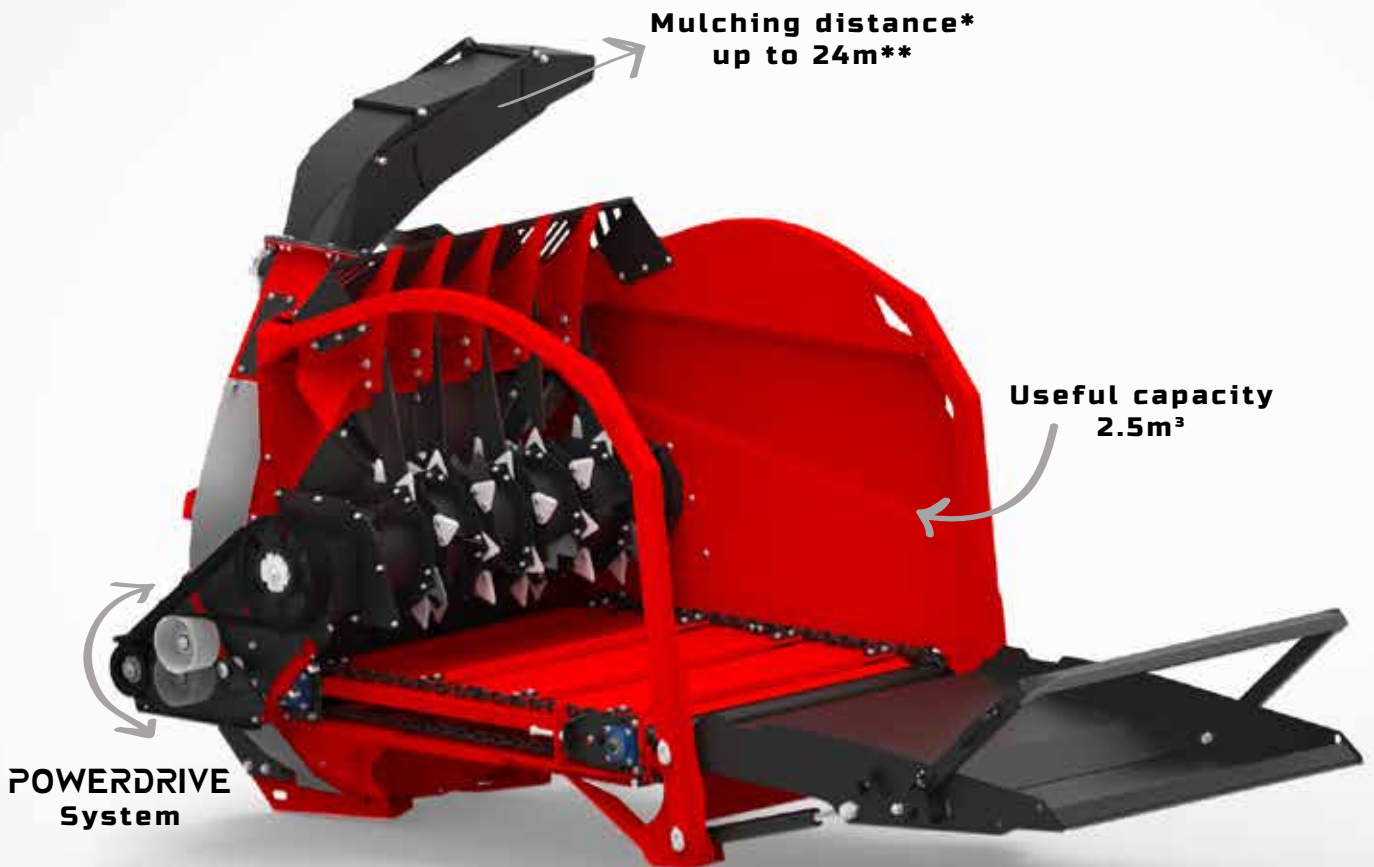

*depending on chute type
**depending on straw quality



HEAD OFFICE

Z.A. De La Touche - 35137 BÉDÉE - FRANCE
T : +33 (0)2 99 06 12 60 // F : +33 (0)2 99 06 12 65
commercial@euromark.fr // www.euromark.fr