

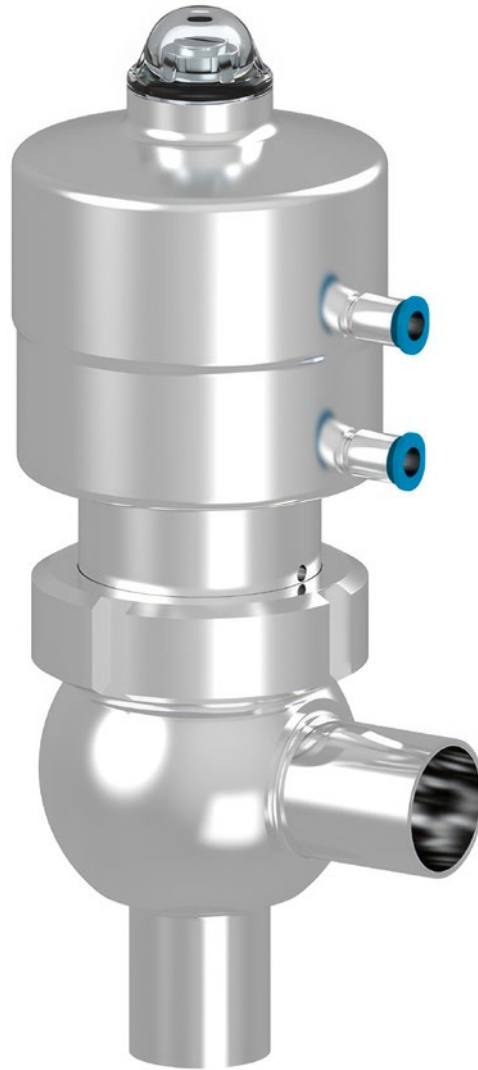

GEA VESTA[®] STERILE VALVES

Reliable hermetic sealing
based on the PTFE bellows design

RETHINK CONVENTIONS



GEA VESTA® Sterile valves are part of GEA's extensive aseptic valve portfolio. The different aseptic valve lines are characterized by their hermetic sealing concept.



The VESTA® Valve line is based on PTFE bellows technology, making it ideally suited to applications in the pharmaceutical, biotech, new food and healthcare. Thanks to the hermetic sealing of the valve stem by a single-piece PTFE bellows, VESTA® Sterile valves reliably separate product-wetted areas from the environment and thus significantly enhance process and product safety. The valve line, which is based on a seat concept, also boasts optimized flow and dead-space-free valve housing design.

The PTFE bellows convinces by its excellent chemical resistance against almost all media and complies with all common standards for various industries, such as FDA 21 CFR 177.1550 and USP class VI. The high-value surface finish ($Ra \leq 0,8 \mu\text{m}$) and CIP/SIP optimized design are other characteristic features.

Benefits at a glance

- Optimized flow and dead-space-free design
- Optimized CIP/SIP cleanability
- Hermetic sealing of the product-wetted area by PTFE bellows
- Defined sealing pre-load by metallic stop
- Valve designed in accordance with EHEDG guidelines
- Self-locking groove nut connection
- Safe and easy maintenance

Application examples



Pharma & healthcare

Sterile processing in areas such as WFI handling and liquid medical infusion (e.g. saline solutions, glucose, insulin)



Food

Sterile processing in areas such as food ingredients (e.g. starter cultures, enzymes)



New food

Plant-based and insects products, sterile processing in cell-based products (e.g. precision fermentation, cultured meat)



GEA VESTA®
Sterile valves
Rethink conventions



VESTA® Product portfolio

VESTA® Shut-off valves type H_A

VESTA® Shut-off valves are used for the controlled shut-off of pipelines in sterile process technology. The modular structure allows the valves to be optimally deployed for the relevant process requirements and capacities.



VESTA® Tank bottom valves type H_A/T

VESTA® Tank bottom valves are used for the controlled shut-off of liquid media in the vessel. They are generally positioned at the lowest point of a vessel, although the valve is also fully drainable when installed horizontally.



VESTA® Valve block types HWA & HXA

VESTA® Valve blocks are compact and versatile sterile valves with two independent actuators. The single-piece housing design enables the merging, separating or diverting of product flow in very tight spaces.



VESTA® Sampling valves type H_A/I

VESTA® Sampling valves are used for aseptic sampling from product pipelines or vessels.



VESTA® Sampling system

Based on a modular design, the aseptic VESTA® Sampling system allows safe, simple sampling at different points in the process line. Its compact structure coupled with the freely selectable degree of automation means it can be readily tailored to customer requirements.

VESTA® Modular valve system

1 Control top

The T.VIS® V-1/V-20 specially developed for VESTA® Sterile valves can be used either as a position indicator or a control top. For larger nominal diameters, control tops T.VIS® M-20 and T.VIS® A-15 are available.

2 Actuator

VESTA® Sterile valves with pneumatic actuators are available in high-performance PPS plastic or stainless steel. The latter have the same design characteristics as plastic actuators and are also autoclavable.

3 Bellows

The patented bellows sealing system safely separates the product-wetted area from the atmosphere in all process steps and seals the valve seat. It includes all of the valve's wear parts and the components required to replace the unit quickly.

4 Housing

Various housing options are available as standard for the different valve types. In addition, the modular valve structure means that customized solutions can also be provided.

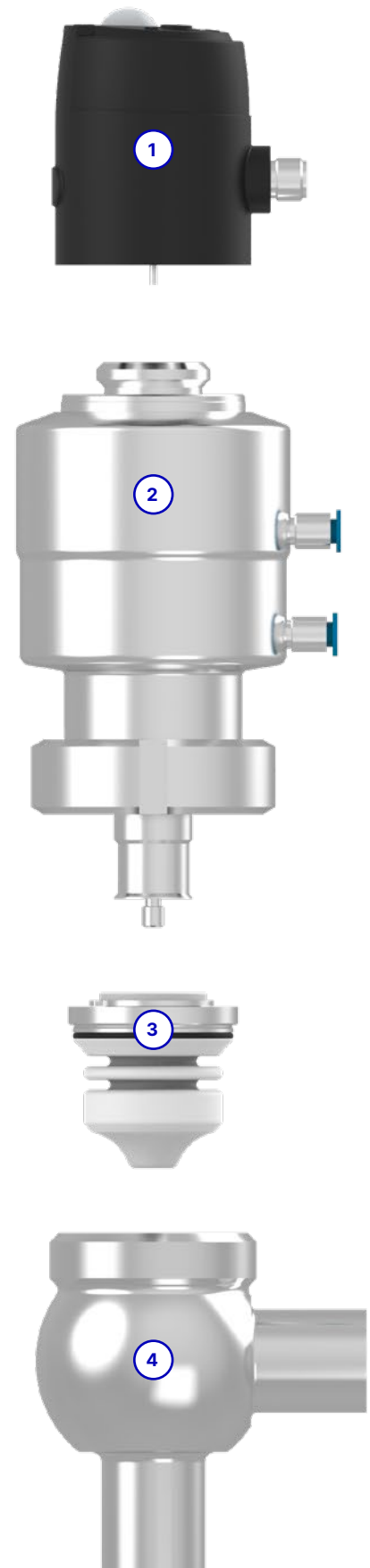

GEA Tuchenhagen GmbH
Am Industriepark 2-10
21514 Büchen, Germany

Tel +49 4155 49-0
Fax +49 4155 2035
gea.com