

50



GPRO
VALPARAISO PALACE & SPA
金浦馬略卡東邑國際度假酒店

Business & Events

FINDEX

⁰⁴ *Introduction*

⁰⁶ *Rooms*

¹¹ *Venues*

²² *Gastronomy*

²⁵ *Spa*

²⁷ *Mallorca*

At GPRO VALPARAISO
there are no LIMITS

EVERY IDEA BECOMES REALITY
IN OUR PARADISE

GPRO VALPARAISO PALACE & SPA

The best option for your *event* in Mallorca

GPRO Valparaiso Palace & Spa has all the services you need for a complete MICE experience at the highest level, with 174 rooms, more than 1.000 m² divided into 9 fully equipped rooms to host the most exclusive events: conventions, congresses, sporting events, product launches, vehicle tests, film shoots and photo shoots.

Private Restaurants for groups

With an 3.000 sqm Spa area,
3 pools (2 outdoor and 1 indoor)

Together with its excellent location in Palma,
GPRO Valparaiso Palace & SPA
is the perfect choice for large events
in private spaces with exclusive treatment,
complemented by
unique and personalised programmes for each client.



ROOMS

Dreamed
REST

ROOMS

Comfort & relaxation

GPRO Valparaiso Palace & SPA offers 174 rooms designed for your comfort and relaxation, all of which have a terrace/balcony with panoramic views of the Mediterranean Sea. Design, technology and luxury are the hallmarks of its facilities, exquisite personalised service and exclusive services.



ROOMS

GPRO Valparaíso

THE ROYAL SUITES

★★★★★

Agate

Jade

Turquoise

Aquamarine

Ruby

Sapphire

Emerald





ROOMS

GPRO Valparaíso

VALPARAISO ROOMS

More than 160 rooms with WIFI, Nespresso coffee machine, safe, complete bathroom with shower or bathtub, minibar, Smart TV, air conditioning and many other modern and carefully designed details in the service of excellence.

The Urban Resort, where luxury and well-being coexist in exceptional surrounding



DEMI SUITE

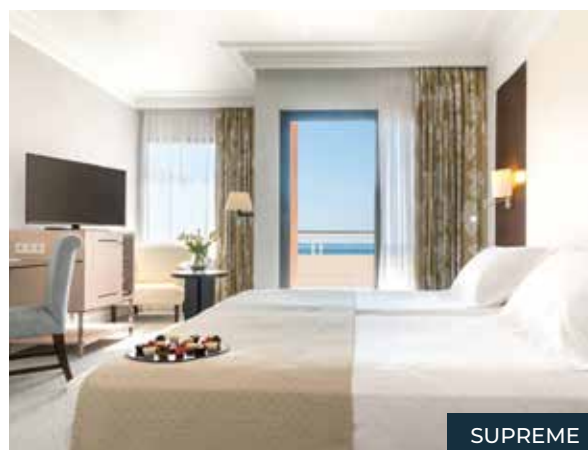

SUPREME

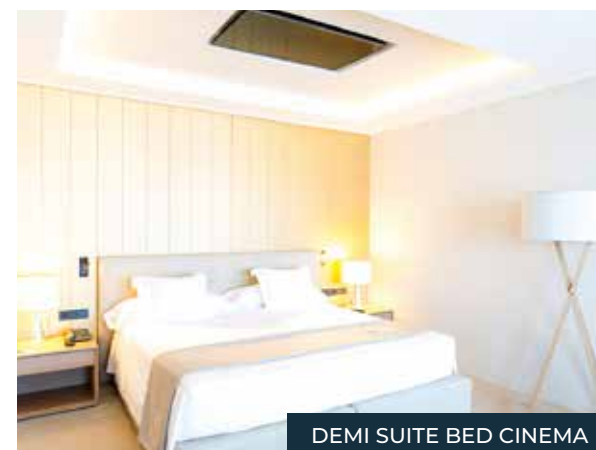

DEMI SUITE BED CINEMA

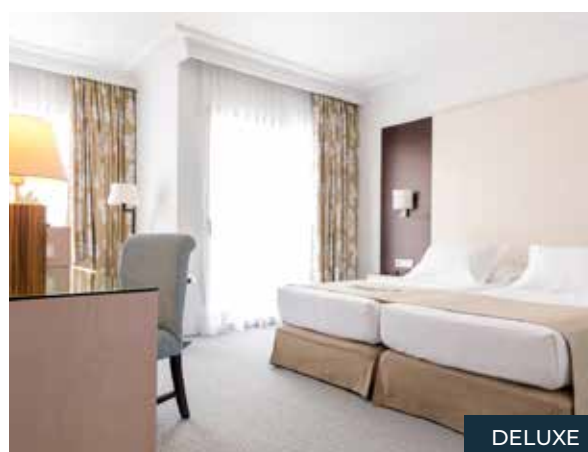

DELUXE



CLASSIC



VENUES

Where MAGIC
HAPPENS

VENUES

Our Venues

GPRO Valparaiso Palace & SPA's diverse range of venues has positioned it as a benchmark in Mallorca's MICE market, becoming the perfect partner for numerous companies to hold their events.

Each of these spaces allows for comprehensive customization and can be enriched with additional activities and proposals that, either marked by the client or recommended by our staff, add a touch of distinction to achieve the event's objectives.

Mallorca Room	Formentera Room	Sant Agustí Room
Menorca Room	Génova Room	Miró Room
Ibiza Room	Executive Room	Porto Pí Room

ROOMS	M2	LENGTH	WIDTH	THEATRE	SCHOOL	U-SHAPE	IMPERIAL	BANQUET	NATURAL LIGHT
Mallorca	450	28*16	4,2	475	275	100	100	300	Sí
Menorca	120	15*8	2,8	100	75	45	45	60	Sí
Ibiza	80	16*5	2,81	80	60	40	40	45	Sí
Formentera	60	12*5	2,8	60	40	32	32	38	Sí
Miró	66	11*6	2,3	-	-	-	20	-	Sí
Porto Pí	110	11*10	2,3	60	60	30	30	60	Sí
Génova	200	22*9	2,3	150	100	50	50	100	Sí
Sant Agustí	60	12*5	2,3	40	30	24	24	-	Sí
Executive	30	6*5	2,62	-	-	10	10	12	-

ROOMS

Mallorca Room

450 m²

Theatre	475	School	275
U-shape	100	Imperial	100
Banquet	300		

Features natural light. Dimensions: 28x16 m (92x52 ft). Height: 4.20 m (13.8 ft).

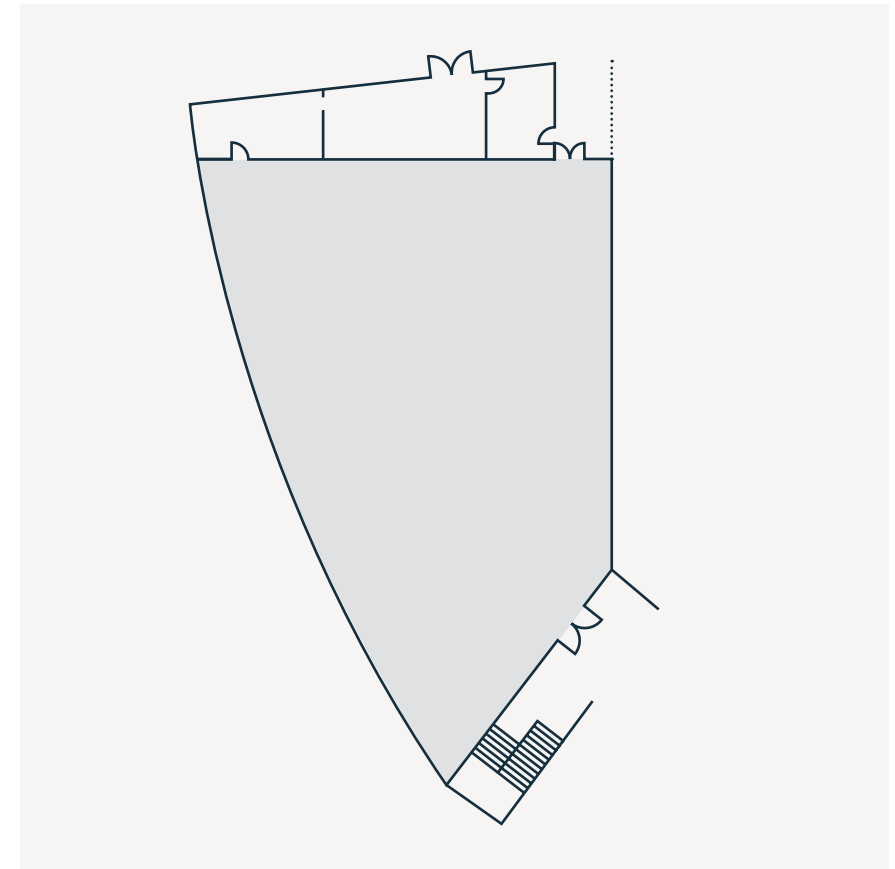
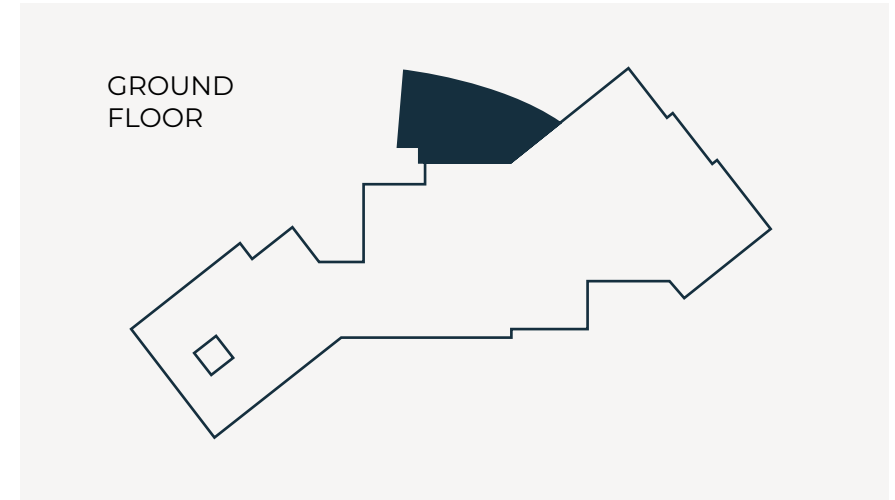

ROOMS

Menorca Room

120 m²

Theatre	100	School	75
U-shape	45	Imperial	45
Banquet	60		

Features natural light. Dimensions: 15x8 m (49x26 ft). Height: 2.80 m (9.2 ft).

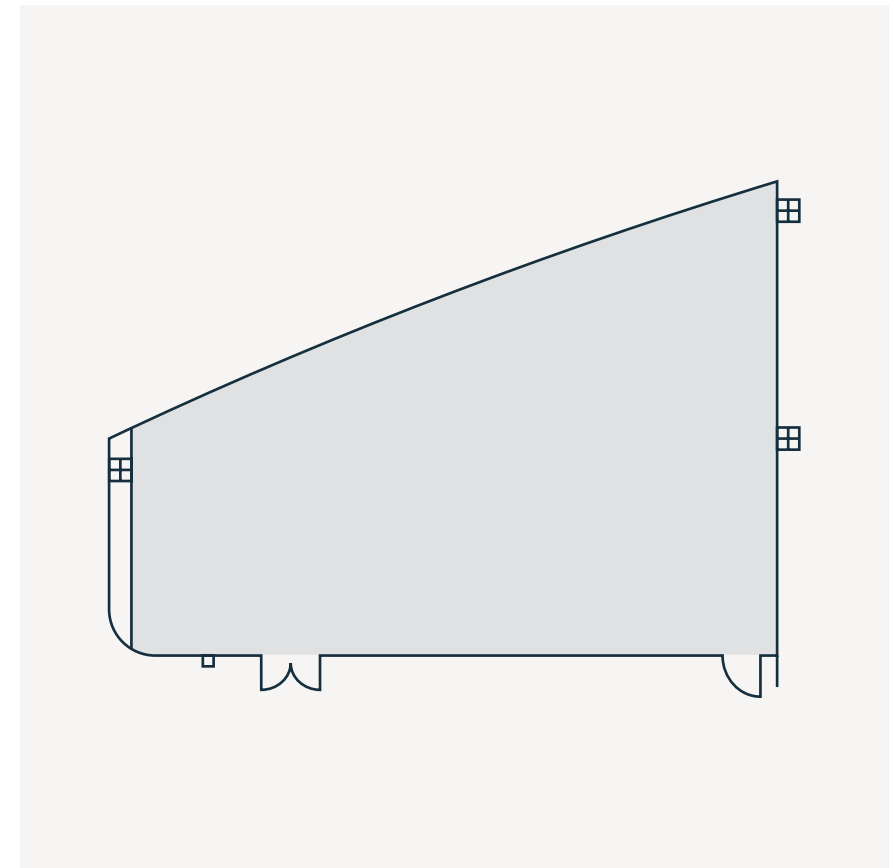
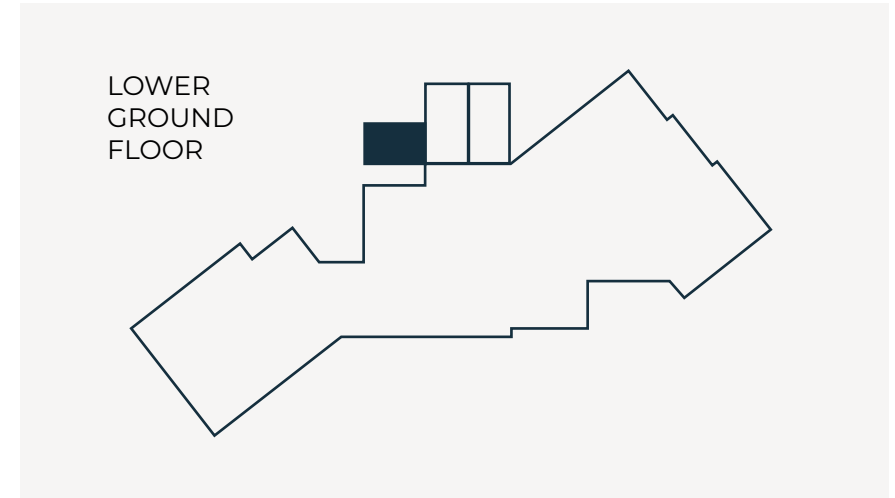

ROOMS

Ibiza Room

80 m²

Theatre	80	School	60
U-shape	40	Imperial	40
Banquet	45		

Features natural light. Dimensions: 16x5 m (52x16 ft). Height: 2.80 m (9.2 ft).

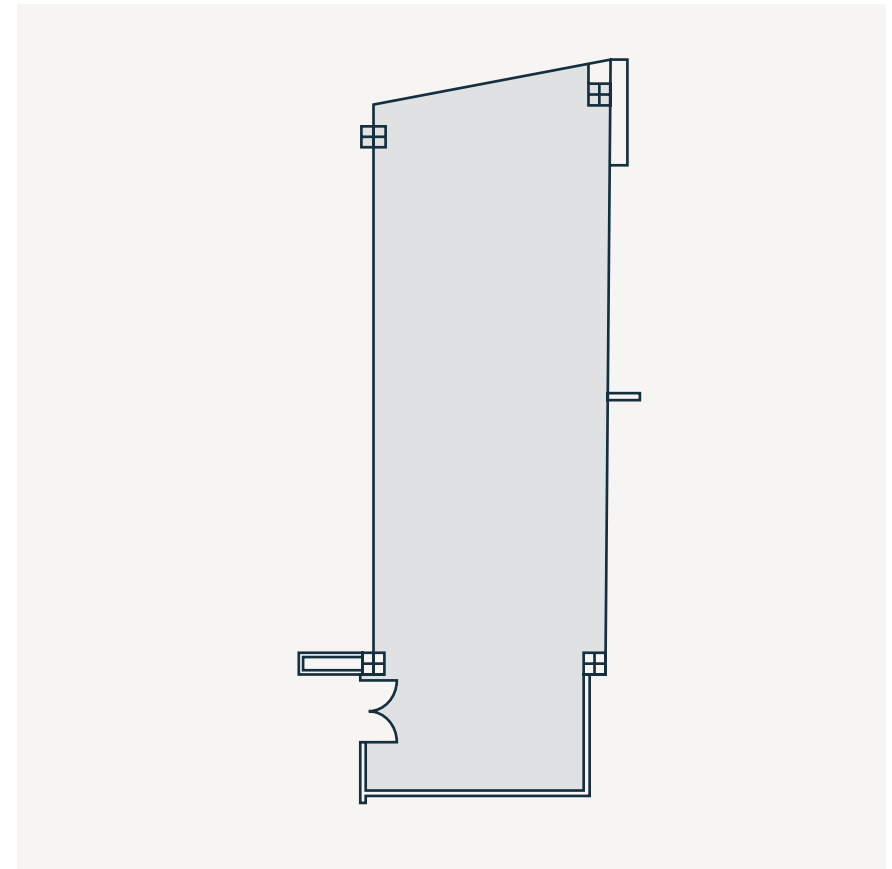
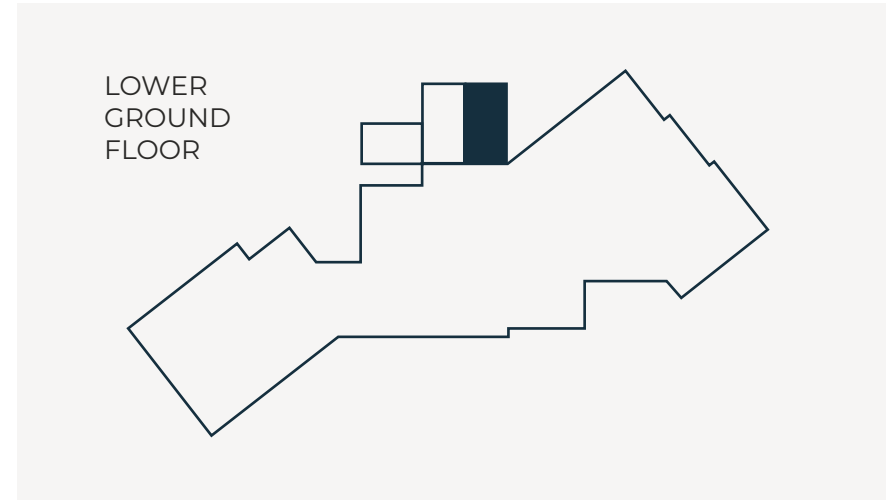

ROOMS

Formentera Room

60 m²

Theatre	60	School	40
U-shape	32	Imperial	32
Banquet	38		

Features natural light. Dimensions: 12x5 m (39x16 ft). Height: 2.80 m (9.2 ft).

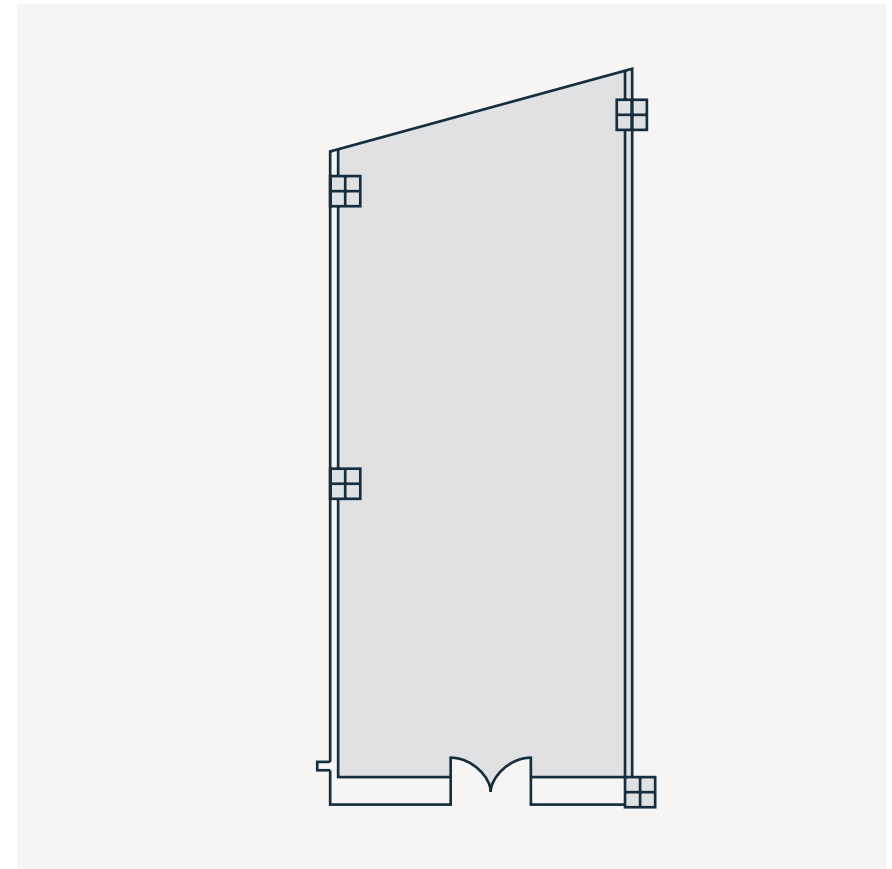
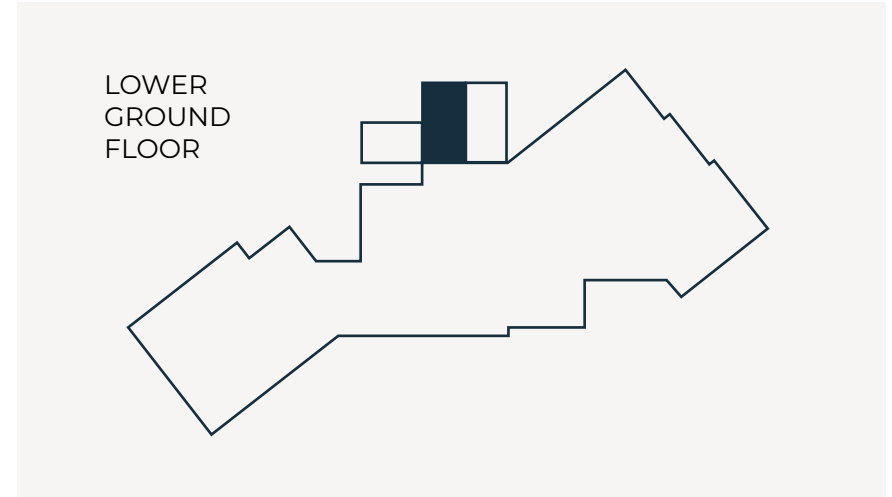

ROOMS

Génova Room

200 m²

Theatre	150	School	100
U-shape	50	Imperial	50
Banquet	100		

Features natural light. Dimensions: 22x9 m (72x30 ft). Height: 2.30 m (7.5 ft).

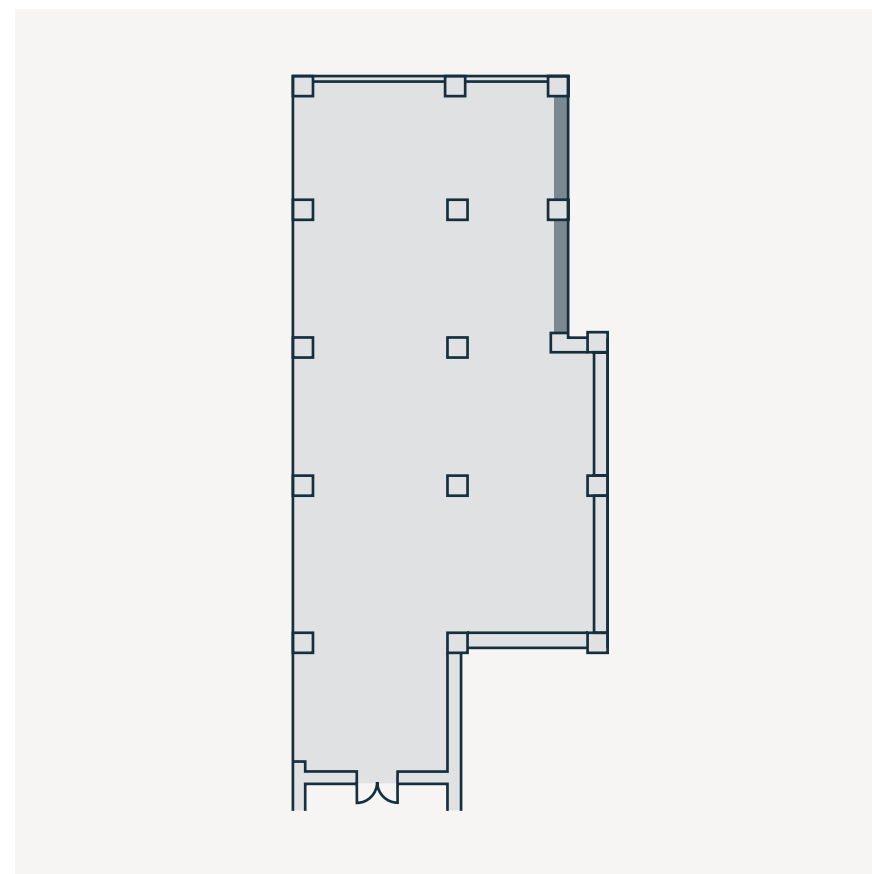
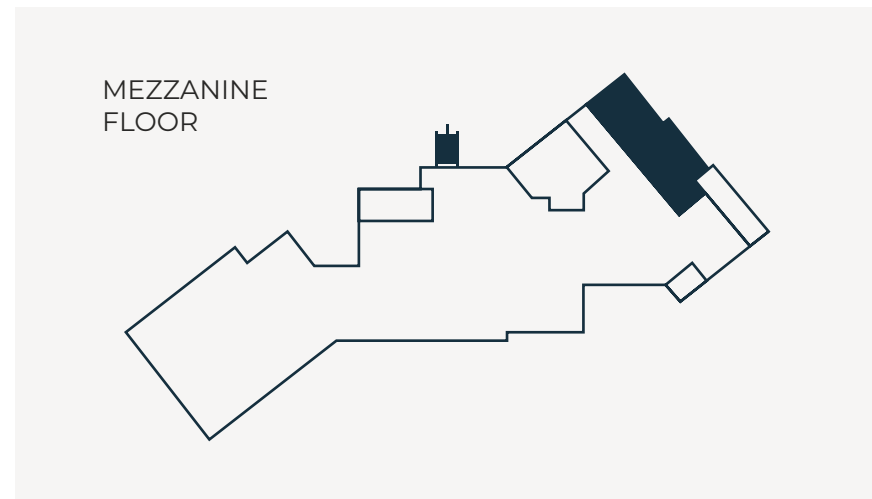

ROOMS

Porto Pí Room

110 m²

Theatre	60	School	60
U-shape	30	Imperial	30
Banquet	60		

Features natural light. Dimensions: 11x10 m (36x32 ft). Height: 2.30 m (7.5 ft).

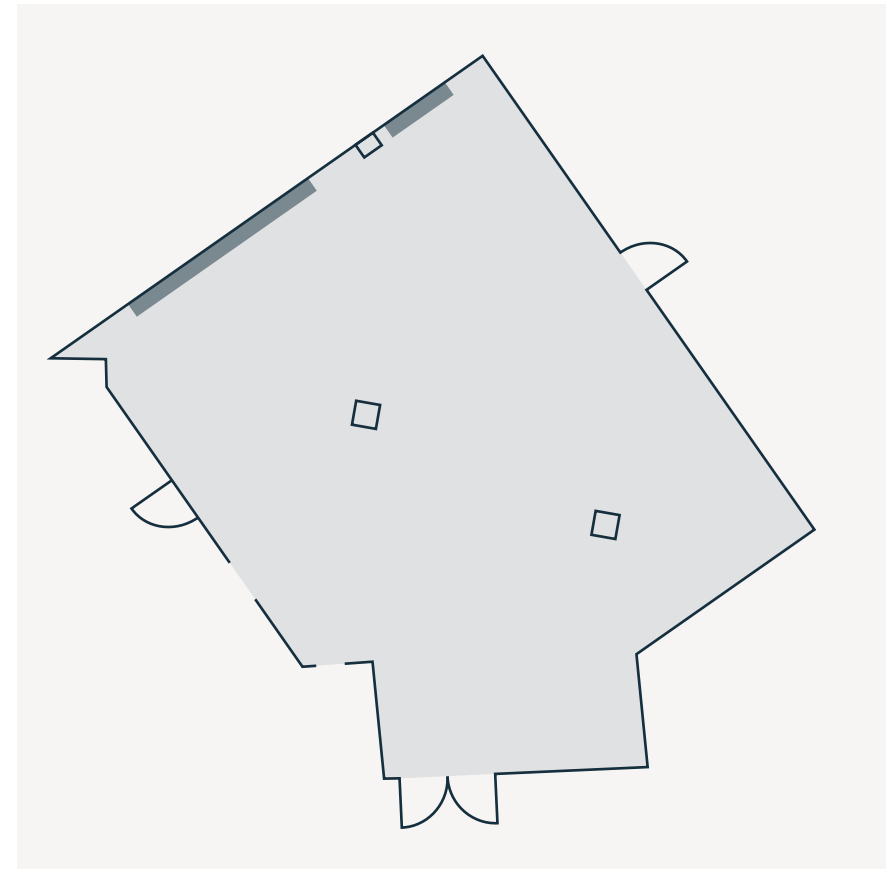
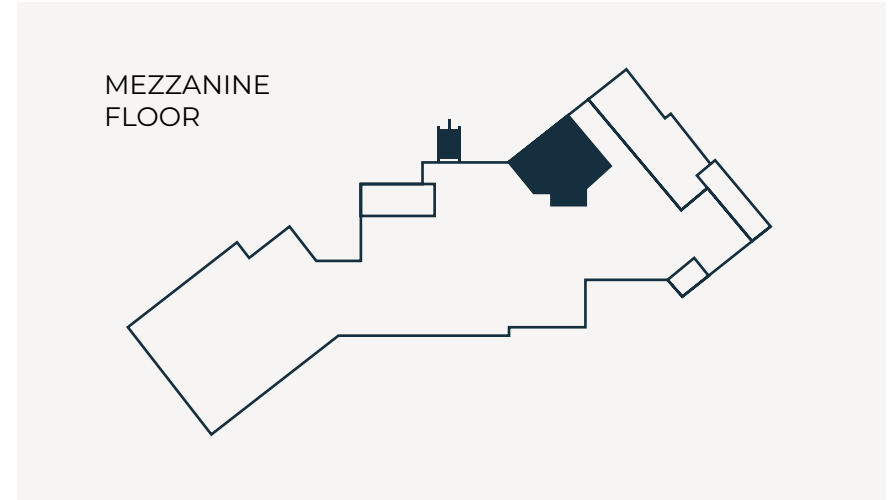

ROOMS

Sant Agustí Room

60 m²

Teatro	40	Escuela	30
Forma U	24	Imperial	24
Banquete	-		

Dispone de luz natural. Medidas: 12x5 m. Altura: 2,30 m.

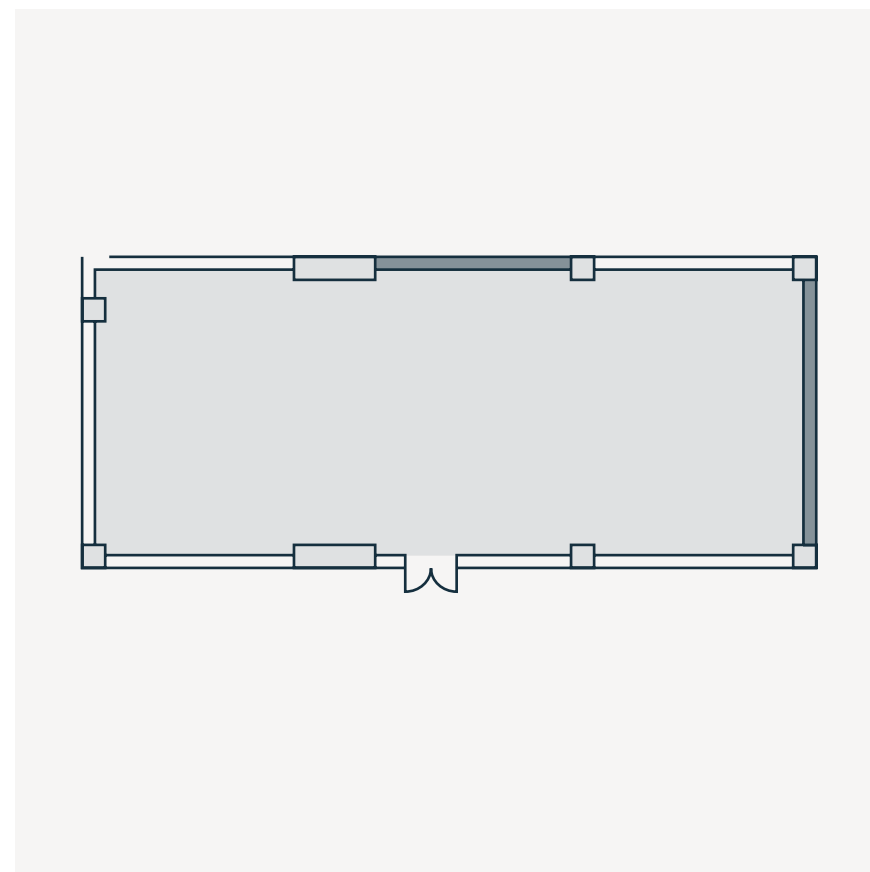
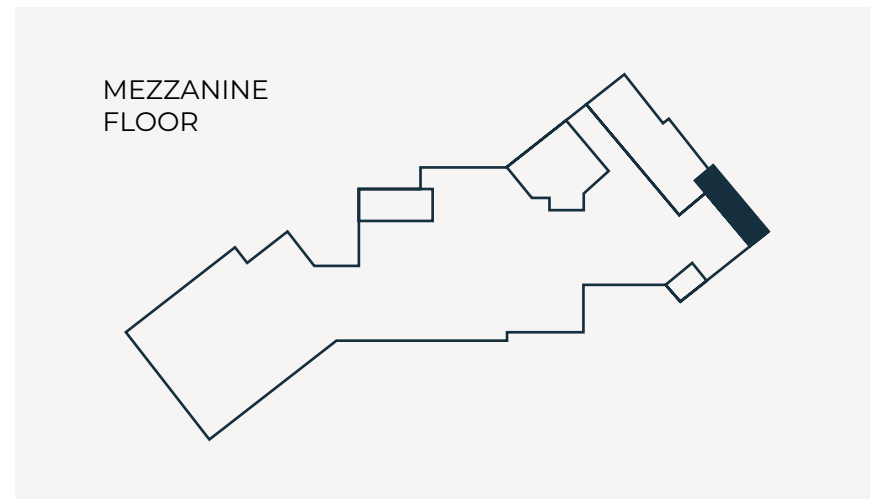

ROOMS

Miró Room

66 m²

Theatre	-	School	-
U-shape	-	Imperial	20
Banquet	-		

Features natural light. Dimensions: 11x6 m (36x20 ft). Height: 2.30 m (7.5 ft).

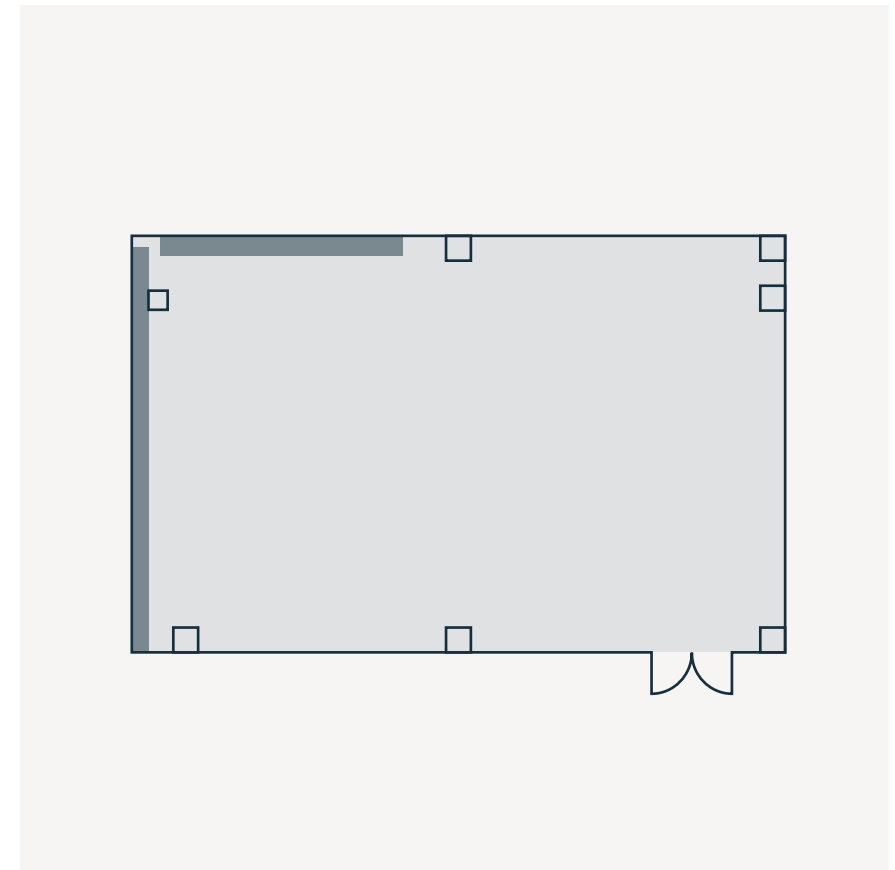
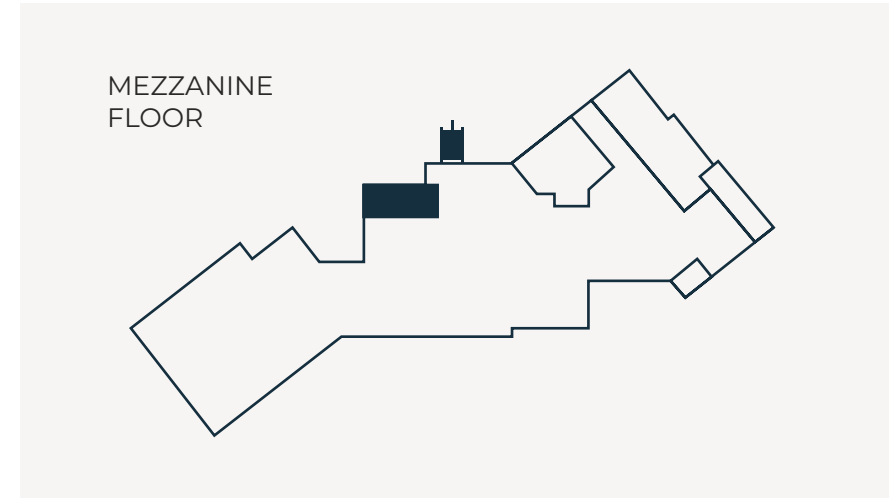

ROOMS

Executive Room

30 m²

Theatre	-	School	-
U-shape	10	Imperial	10
Banquet	12		

Dimensions: 6x5 m (20x16 ft). Height: 2.62 m (8.6 ft).

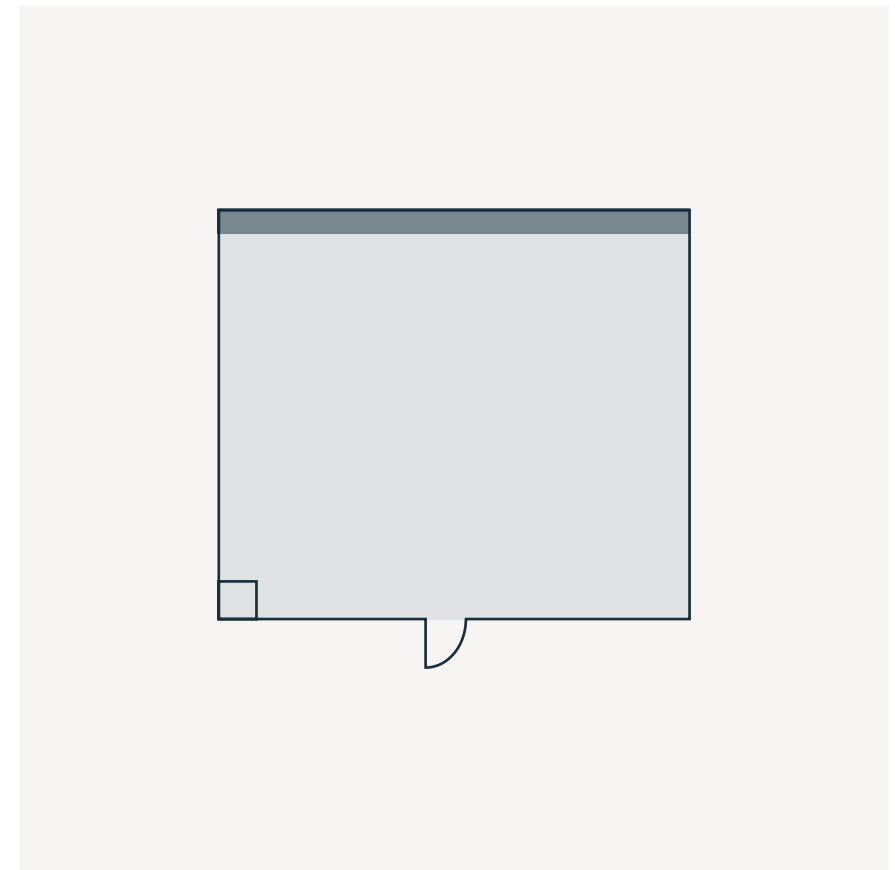

GASTRONOMY

A TASTE OF *paradise*



GASTRONOMY

Indoor areas

Mallorca Room

Modern space for gala dinners, breakfast colloquia and lunch or dinner meetings. It offers natural light. Maximum capacity of 250 people for banquets. Stage, screen and projector included.

Royal Room

Classically styled with external projection. Ideal for finger buffets, aperitifs and coffee breaks. Maximum capacity of 250 people standing.

Marivent Restaurant

Ideal for business lunches and dinners, finger buffets and aperitifs. A glazed room with panoramic views of the Bay of Palma, located on the first floor, with a maximum capacity of 200 people for banquets.

Paraíso Restaurant

Private space for group lunches from 1:00 p.m. onwards. Warm and friendly atmosphere, close to the main entrance.



Outdoor areas

DAO Pool Restaurant

For Finger Buffets or welcome drinks.



Pool Terrace

For barbecues or buffet dinners.



Infinity Terrace

With breathtaking views over Palma bay.





SPA
HEAL HEALTH HARMONY

SPA

OASIS *to* DISCONNECT

SPA

HSPA

by GPRO Valparaiso Palace & SPA

The perfect and necessary complement to your stay, a space created to disconnect, relax, get in shape and forget about the stress of the day.

Heated pool
Indoor and outdoor

Finnish sauna

Gym

Hammam

Jacuzzi

Steam room

Ice cave

Inhalation sauna

Herbal sauna

Sensory shower

OTHER SERVICES

Meditation room

A world of sensations, serenity and inner peace.

Hairdresser

Relaxation room

Tranquillity, silence and harmony on water beds.



*If it's important
to you, it's
important to us*



MALLORCA

OUR HOME



MALLORCA

Our surroundings

GPRO Valparaiso Palace & SPA in Palma de Mallorca has a privileged location opposite the Mediterranean Sea, surrounded by the forest and the Bellver Castle.

Mallorca has an ideal climate with an average temperature of 22° Celsius. Its connections to the main European airports make the island one of the best destinations for events all year round.

DISTANCE TO POINTS OF INTEREST

Fundació Miró Mallorca	850 m
Marivent Palace	900 m
Bellver Castle	950 m
Cala Major beach	1.000 m
Mallorca Cathedral	3,5 km
Palma de Mallorca Airport	12 km



22°C AVERAGE TEMPERATURE

MALLORCA

Our surroundings

With its enviable location, Mallorca offers more than 200km of fine golden sand beaches and stunningly clear, shallow waters. Its cliffs and small, secluded coves are a delight to the senses all year round, thanks to the warm Mediterranean climate.

In addition to its rich cultural and leisure offer, the island has established itself as one of the most suitable destinations for any type of business event, congress or product launch.



Our commitment with

THE ENVIRONMENT

is more than just words

Every year since 2006, GPRO Valparaiso Palace Hotel & Spa has obtained the converted ISO 14001 certification of environmental quality management.

Furthermore, we have also received the distinction of “Eco-Resort” and “Umwelt Champion (Environmental Champion)” awarded by the tour operator TUI.

One of our fundamental principles is too efficiently and effectively management our environmental with these values.

What does GPRO Valparaiso Palace do to protect the environment?

1. We manage our pollution and waste

- We classify and separate the garbage for recycling
- We control our atmospheric emissions
- We monitor the noise we produce
- We delivered hazardous waste to authorized managers

2. We save water

- We install flow restrictors on faucets and shower
- We change the towels according to customer ecological criteria
- We watering during the peak insolation hours
- In our gardens, native plants dominate

3. We save energy

- We take advantage of natural light
- We use automatic sensor switches
- We use energy efficient light bulbs
- We control the temperature by thermostats
- We have 10 places to recharge electric vehicles

4. We think green when we purchasing

- We apply environmental criteria when buying
- We give priority to local products to reduce our carbon footprint
- We reduce the consumption of toxic products
- We use recycled paper or bleached without chlorine

5. We acquire environmental knowledge and attitudes

- We have an environmental training plan for our staff
- We are ready to respond to environmental emergencies
- The hotel has an environmental manager

6. We are committed to the environment

- We consider complaints and suggestions from our customers
- We obtain environmental certifications in our establishment
- We are members of the “Red de Hoteles Sostenibles Baleares” (Balearic Sustainable Hotel Network) <http://xarxahotelsostenibles.com/>

Certificado ES14/17067

El sistema de gestión de

GPRO VALPARAISO PALACE & SPA



C/ Francisco Vidal Sureda, 23, 07015 Palma de Mallorca, Mallorca

ha sido evaluado y certificado que cumple con los requisitos de

ISO 14001:2015

Para las siguientes actividades
Prestación de servicios de alojamiento y restauración.

Esta certificación es válida desde 25 de enero de 2024 hasta 23 de diciembre de 2026 y su validez está sujeta al resultado satisfactorio de las auditorías de seguimiento.
Edición 4, Certificada desde 23 de diciembre de 2014

Expiración del ciclo anterior 23 de diciembre de 2023
Auditoría de renovación 17 de noviembre de 2023

Autorizado por
Dirección de Certificación
SGS International Certification Services Iberica, S.A.U.
C/Trinidadocho, 26, 28042 Madrid, España
t +34 91 313 8115 - www.sgs.com



Este documento es un certificado electrónico subscrito para el uso comercial del Cliente únicamente. Está permitida la versión impresa del certificado electrónico y se considera como una copia. Este documento es emitido por la Compañía sujeta a las Condiciones Generales de SGS de los servicios de certificación disponibles en los términos y condiciones SGS. Se presta especial atención sobre las cláusulas de responsabilidad, indemnización y jurisdicción que contiene. Este documento está protegido por derechos de autor y cualquier alteración, falsificación o modificación no autorizada de su contenido es ilegítima.

Página 1 / 1



Reconoce a

GPRO Valparaiso Palace & SPA

Por su compromiso:

- Con el desarrollo sostenible de su territorio, la cohesión social y el modelo Regenerativo Competitivo alineado con los 17 Objetivos de Desarrollo Sostenible de la Agenda 2030 de Naciones Unidas.
- Con la sensibilización y la formación de su equipo como Hotel Regenerativo Competitivo.
- Con la difusión de sus compromisos y valores a través de su carta corporativa
- Con la puesta en marcha su Plan Estratégico Regenerativo Competitivo 2022.

En Madrid, a 13 de mayo de 2022



Victor Fernández
Co-Fundador y director de Proyecto



CERTIFICADO DE INSCRIPCIÓN
Registro de huella de carbono, compensación y proyectos de absorción de CO₂ del Ministerio para la Transición Ecológica y el Reto Demográfico

GPRO HOTEL VALPARAISO & SPA

Año de cálculo 2020

Tipo de sello CALCULO

Alcances 1+2

Limites Se incluyen las actividades de servicios de alojamiento, restauración y oficinas realizadas en las instalaciones del hotel GPRO VALPARAISO PALACE HOTEL & SPA ubicado en Palma (Islas Baleares).



Valvanera V

Valvanera Ulargui Aparicio
Directora General
Oficina Española de Cambio Climático
Ministerio para la Transición Ecológica y el Reto Demográfico

Fecha de inscripción: 28/06/2022
Cód. huella de carbono: 2022-00804

50



GPRO
VALPARAISO PALACE & SPA
金浦馬略卡東邑國際度假酒店

Lorenzo Bauzá
Sales Manager

grupos@gprovalparaiso.com
+34 971 400 300