

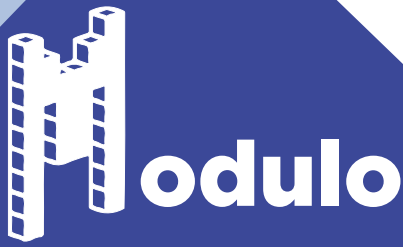

MADE IN FRANCE

## Dishwasher tables range



**The dishwasher  
tables you  
need !**

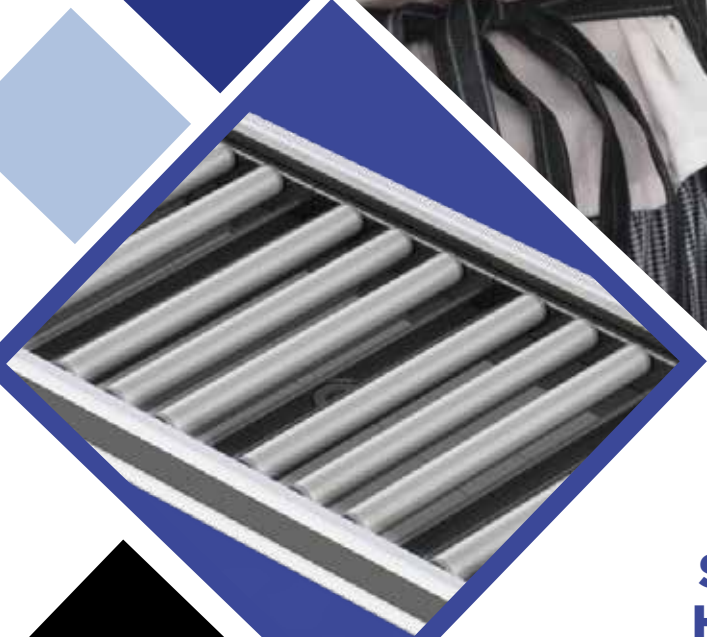

Exclusivity !

**Stainless steel construction with  
HDPE500 sides and sliding areas**  
(high density polyethylene)



*Many possible  
configurations*



*Easy and  
intuitive  
assembly*



*Fast delivery*

# New range of roller sliding tables

**4+**  
 HYGIENE  
 ERGONOMICS  
 SAFETY  
 SUSTAINABLE\*  
(\*develop without destroying)



Clever combinations of standard elements to quickly adapt to all your project specifications.



**Stainless steel construction with HDPE500 sides**  
 (high density polyethylene).



**Time savings on installation :**

- Easy mounting with sealed clamps
- V-grooves under each table for quick and safe run of the limit switch cable.

## Why choose HDPE500 ?



No risk of cuts for installers or users during cleaning.



The use of HDPE allows for a perfect seal between each table, which no longer has to be made by the installer.



Durable and efficient (100 year service life).



High resistance to temperature variations, corrosion, abrasion and most acids and solvents.



Unbreakable : extremely resistant to external shocks.



Lightness : easy handling.



Ecological : infinitely recyclable material with a small environmental footprint.

# Technical characteristics

This range consists of tables (straight or curved) in stainless steel and HDPE as well as full stainless steel modules.

Each table is independent (1 drain with siphon and PVC bung per table).

Our tables consist of a stainless steel base with a diamond top and drain, stainless steel edges, and 4 HDPE glide strips.

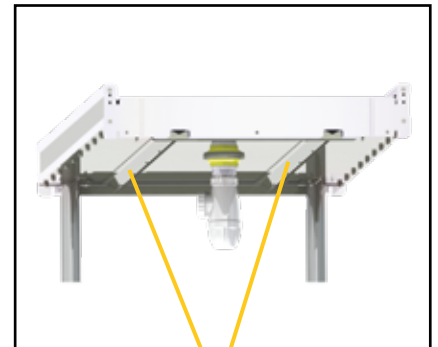
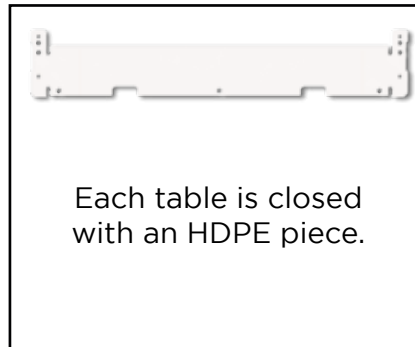
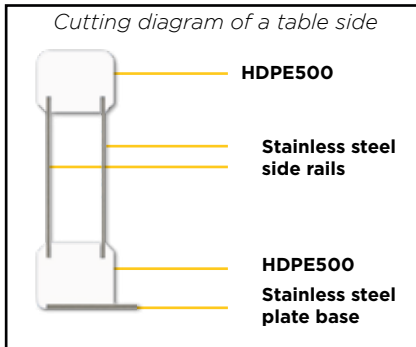

Each table consists of a series of removable stainless steel frames (length 280 mm) each equipped with 3 PVC rollers.

All our modulo tables are equipped with 2 V-shaped cable ducts so that the electric cable for the limit switch connection (TLMFC) can be placed on the right or left side quickly and safely.



3 roller frame :

- Small footprint : ideal for the washing machine
- Lightness for easy handling to reduce musculoskeletal disorders (MSD).

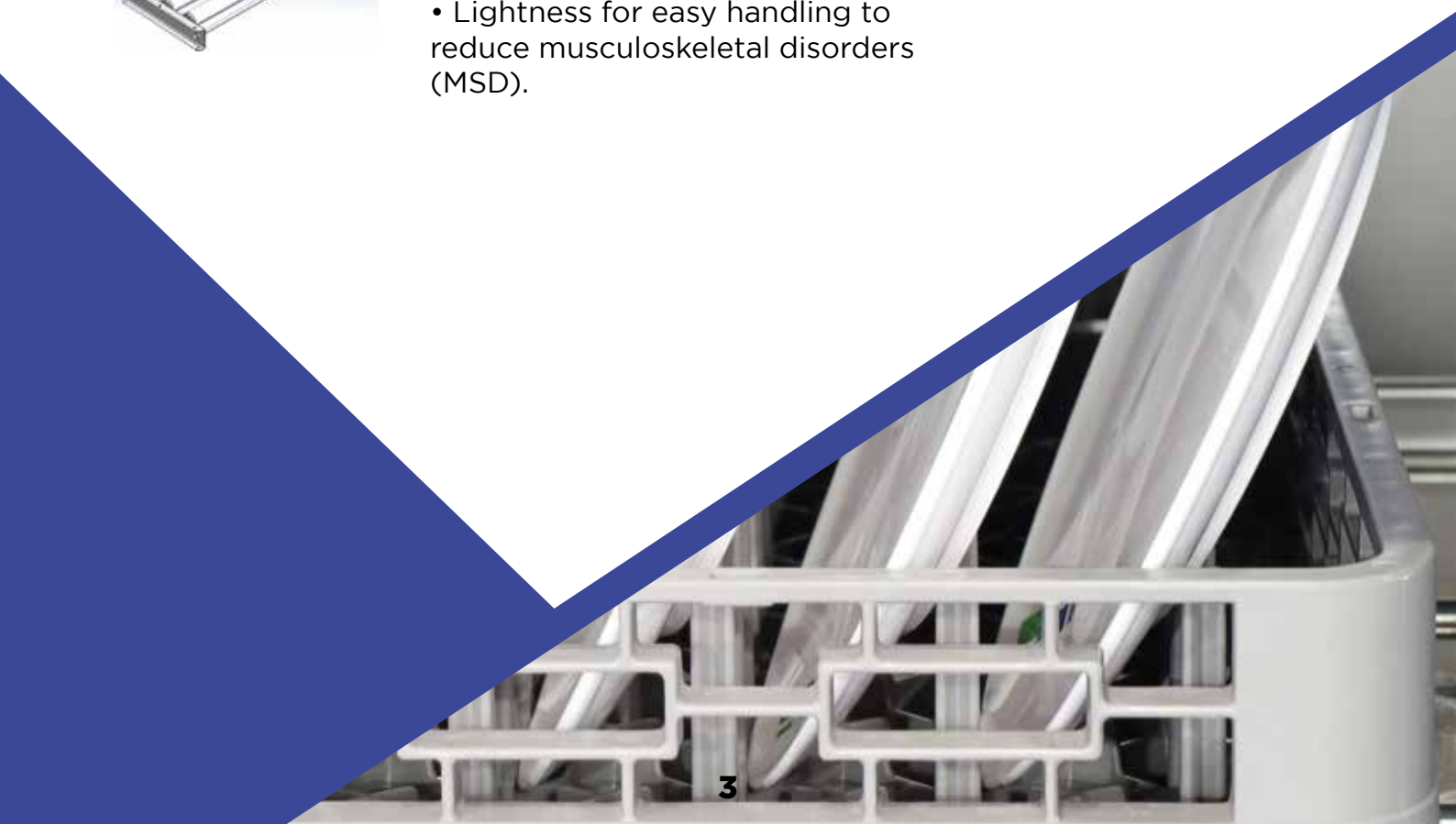



## Roller tables

Ref.	Length (mm)	Number of racks (500x500 mm)	No. of stainless steel frames (length 280 mm with 3 PVC rolls)	Number of hoops bases	Weight (kg)
<b>TLM620</b>	620	1	2	1	18
<b>TLM900</b>	900	1	3	1	24
<b>TLM1180</b>	1180	2	4	1	30
<b>TLM1460</b>	1460	2	5	1	36
<b>TLM1740</b>	1740	3	6	1	42
<b>TLM2020</b>	2020	4	7	2	51

All of the above straight tables are supplied flat with a single hoop base (except TLM2020 / 2 hoops).

Delivered flat

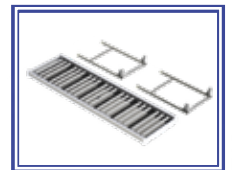

**TLM620**



**TLM1180**



**TLM2020**

- Stainless steel tray, interior width 550 mm
- Base ; in Ø 38 mm round stainless steel tube, mounted on adjustable ABS jacks
- Centre outlet with drain 40/49 mm
- PVC rollers length 500 mm and Ø 40 mm, stainless steel pins and balls, mounted on frame with crushed folds
- Stainless steel legs and frames, PVC rollers and HDPE sides
- Designed for the sliding of 500 x 500 mm baskets
- Sliding height : 875 mm (adjustable to +/- 15 mm)
- Supplied with drain and PVC trap
- All our modulo tables are equipped with V-shaped cable ducts as standard.

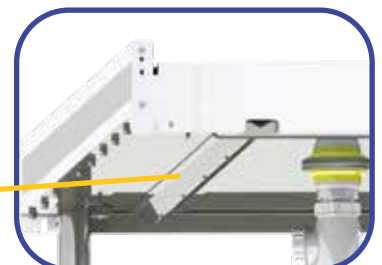



# Roller tables

## with low stainless steel shelf with racks

Ref.	Length (mm)	Number of racks (500x500 mm)	No. of stainless steel frames (length 280 mm with 3 PVC rolls)	Number of hoops bases	Weight (kg)
<b>TLMEG620</b>	620	1	2	2	23
<b>TLMEG900</b>	900	1	3	2	30
<b>TLMEG1180</b>	1180	2	4	2	36
<b>TLMEG1460</b>	1460	2	5	2	42
<b>TLMEG1740</b>	1740	3	6	2	48,5
<b>TLMEG2020</b>	2020	4	7	2	55

Delivered flat

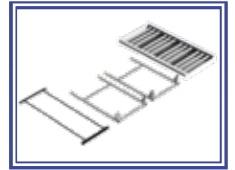

- Delivered with a low stainless steel shelf with racks
- 2 hoops bases with ABS jacks included



TLMEG620



TLMEG1180



TLMEG2020



## Low stainless steel shelf rack only

delivered without roll bar\*

Ref.	Length (mm)	Weight (kg)
<b>EGM620</b>	620	1,5
<b>EGM900</b>	900	1,9
<b>EGM1180</b>	1180	2,3
<b>EGM1460</b>	1460	2,7
<b>EGM1740</b>	1740	3,1



*\*Please note : if the modulo table has only one hoop base, remember to order a second hoop base (see page 9).*



# Roller table with sink

Ref.	Length (mm)	1 tank 1 backrest and 1 backplash	Number of hoops bases	Weight (kg)
<b>TLMD44</b>	620	1 sink of 400x400xP250 mm	1	22
<b>TLMD54</b>	620	1 sink of 500x400xP250 mm	1	23



### Delivered with a hoop base

*(to be mounted directly on the table if TLMD44 or on the previous straight table if TLMD54).*



### Demonstration

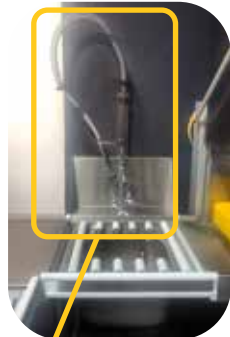
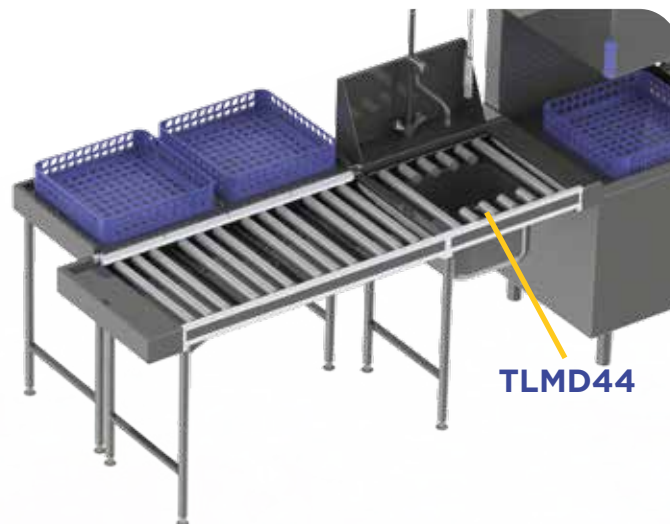

### Available options :

*Hand shower support pole (ref. OPLMA) + mixing shower (ref. PLADMC)*



# Roller curves

As a rule, the design of the roller curve is identical to the straight table. The HDPE parts are machined in the shape of a curve and contain edges that follow the shape.

**The roller frames are specific to this model to follow the curved shape.**

Sliding height : 875 mm

Ref.	Dimensions (mm)	Number of hoops bases	Weight (kg)
<b>TLMA90</b>	900 x 900	1	27



**Demonstration**

**SMALL FOOTPRINT !**

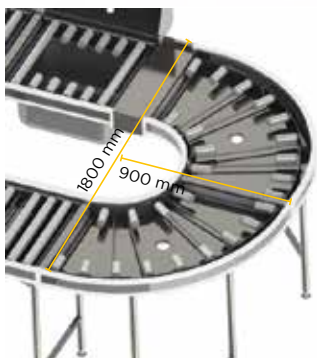
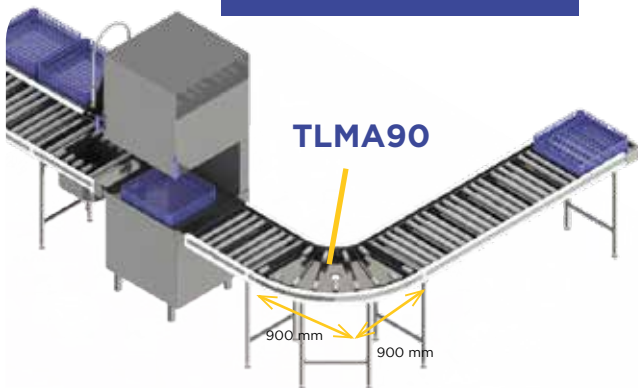

*To make a 180°, combine 2 x TLMA90*



# Angle return module

This smooth stainless steel module allows the installation in « L » shape without modification of the standard straight tables hanging on it.

Ref.	Dimensions (mm)	Number of hoops bases	Weight (kg)
<b>TLMC</b>	600 x 600 x H 875	1	14



**TLMC**

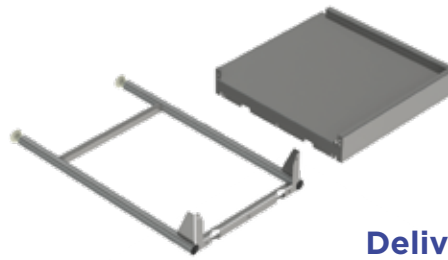

**Delivered with a hoop base**



## Demonstration



**TLMC**

**90° ANGLE !**





# Options and accessories

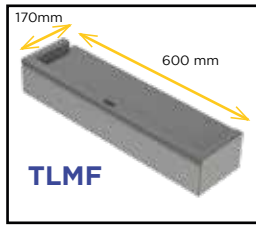

**Stainless steel table lock**  
 In the case of the last table, it is necessary to close it with this smooth stainless steel module.  
 Hanging with M5 screws (supplied).

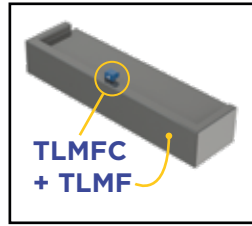

**Paddle switch**

*The TLMFC limit switch must be installed on an existing TLMF lock (to be ordered at the same time or afterwards).*

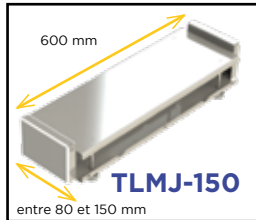

**Smooth connection « Table extension »**

It is sometimes necessary to extend a table to fit the size requirements of the job site. We can add a spacer module of the desired length (from 80 to 150 mm to be specified when ordering). Tool-free assembly by tightening knurled hand screws.

*Can be positioned anywhere between two straight tables*

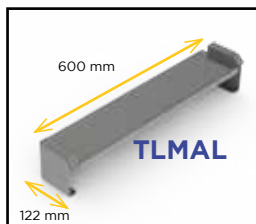

**Standard washing machine hook**  
 Hanging with M5 screws (supplied).

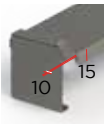

Side of the standard hook

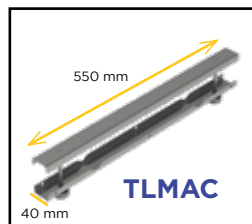

**All stainless steel jaw**

Allows to hang 2 roller tables between them. Tool-free assembly by tightening bolts and screws.

*Must be ordered separately when purchasing 2 modulo tables to be connected together.*



**Specific washing machine hook**

*Thank you to give the references of the dishwasher imperatively with the order.*

Hanging with M5 screws (supplied).

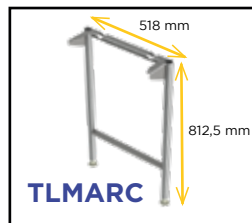

**Frame for modulo standard table**

For sliding area at 875 mm height. Other sliding heights possible on request : please contact us.

*In case of addition of low shelves after the construction or in certain configurations, it will sometimes be necessary to order an additional single arch.*

Ref.	Dimensions (mm)	Weight (kg)
TLMF	600 x 170	4,6
TLMFC	Limit switch	
TLMJ-150	entre 80 et 150	5
TLMAC	550 x 40	1,5
TLMAL	600 x 122	2,6
TLMALS	customized	
TLMARC		3



TLMF TLMFC



TLMAL



# Tables for lateral connection on modulo table with standard rollers

In a washing up environment, the good connection between the deposit tables and the roller tables is essential to guarantee a good working ergonomics to the users and to allow an optimal sliding of the baskets towards the operator.

Our Modulo deposit tables are designed to fit perfectly with the roller tables.

Depending on your location (with or without a low wall), our deposit tables can be connected laterally to the roller tables.

*Please provide a drawing of your project configuration when ordering, so that we can make the necessary custom adjustments.*

Width : 550 mm (for 500 x 500 mm basket) - Other customised widths : please contact us

Ref.	Designation Deposit table	Tray dimensions	Number of hoops bases
<b>TLMT-11</b>	for 2 baskets 500 x 500	L 1150 x P 577 mm	2
<b>TLMT-16</b>	for 3 baskets 500 x 500	L 1650 x P 577 mm	2
<b>TLMT-21</b>	for 4 baskets 500 x 500	L 2150 x P 577 mm	3

**TLMT-11 connected to a TLM1180 for lateral sliding of baskets**

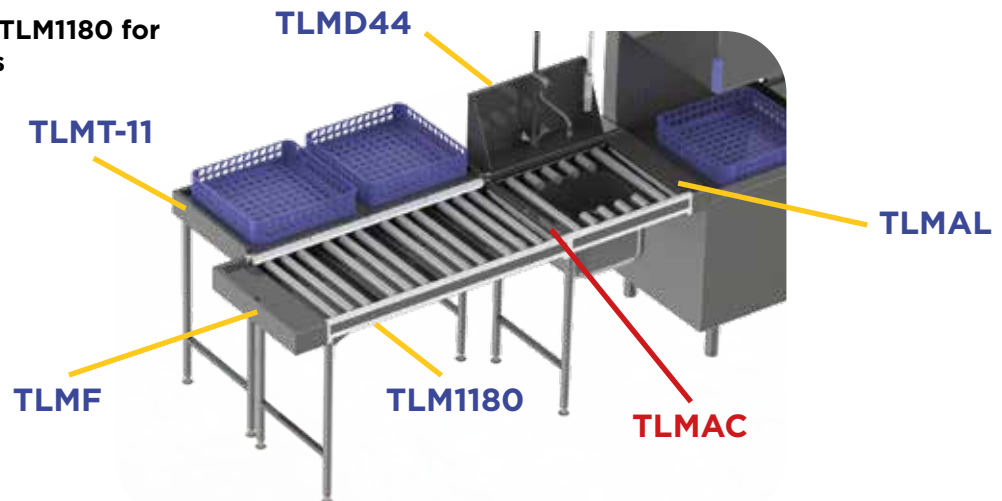

**TLMT-16 connected to a TLM1740 for lateral sliding of baskets**

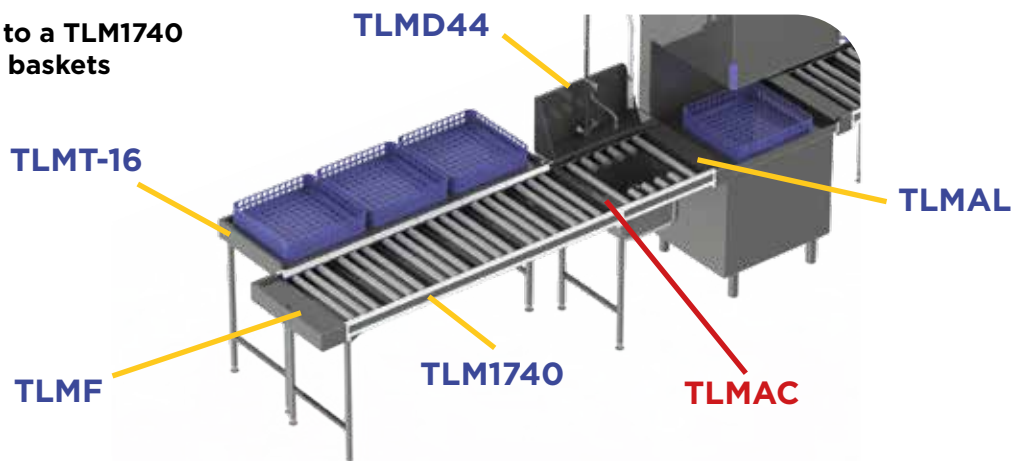

# Examples of projects

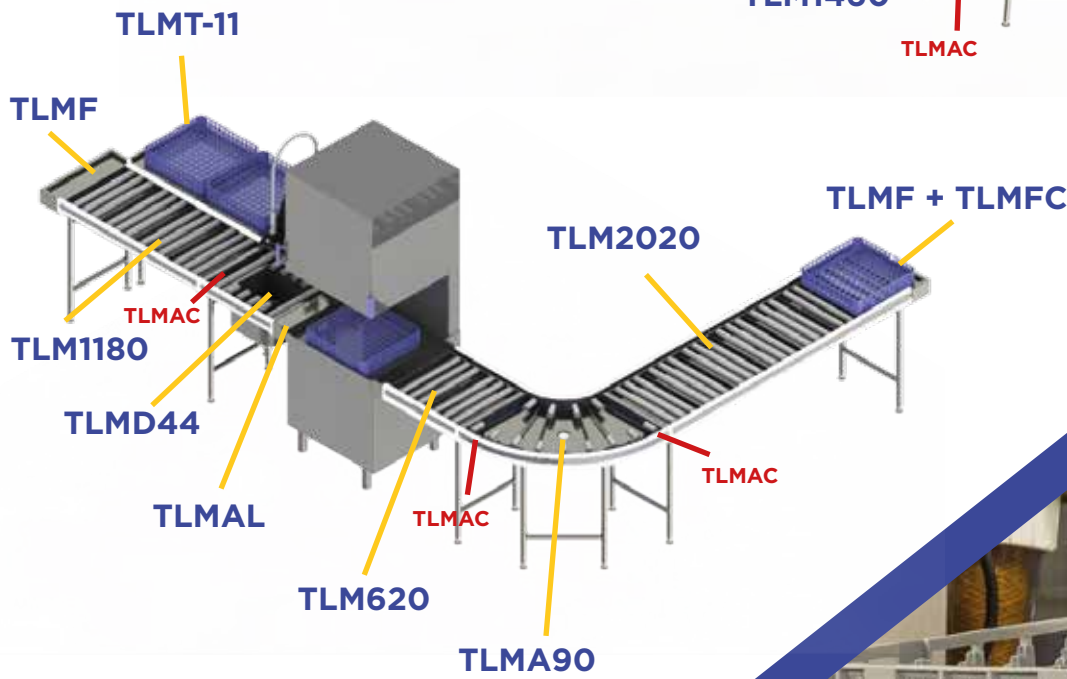
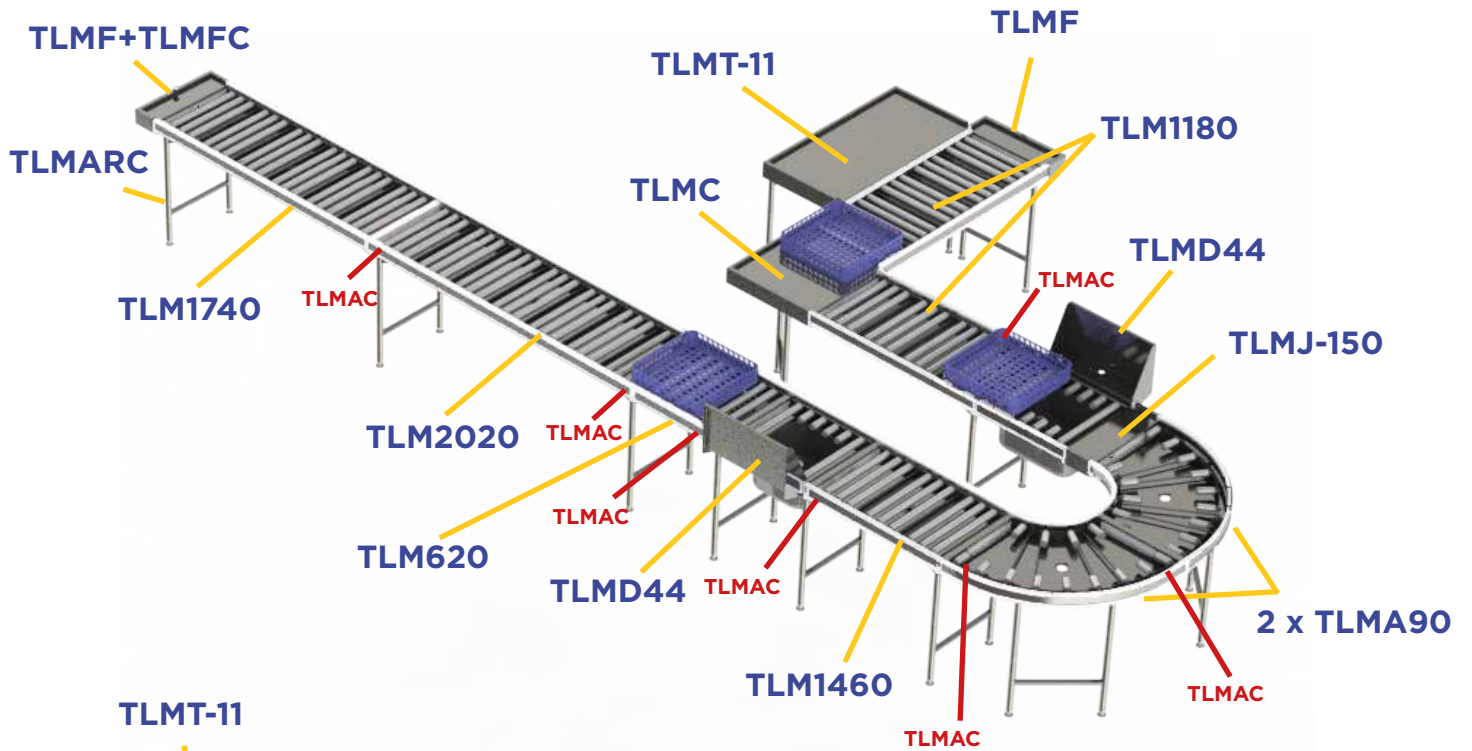

MADE IN FRANCE



[sofinor@sofinor.com](mailto:sofinor@sofinor.com)



+33 3 20 10 34 10



Parc d'activités de la Houssoye  
Rue Ambroise Paré  
59280 Bois-Grenier  
FRANCE



[www.sofinor.com](http://www.sofinor.com)