



PRODUCT CATALOGUE



YOUR *fresh*
EXPERIENCE



20
YEARS
MADE IN FRANCE

ditosama.com



Dito Sama: Excellence at the Service of Dynamic Food Preparation

For nearly 80 years, we have supported **food industry professionals** with one of the **most comprehensive ranges** of equipment on the market—renowned for its outstanding **quality** and full compliance with the strictest **hygiene and safety** standards.











Our mission? To preserve the freshness of ingredients and deliver a true homemade experience that delights even the most demanding customers.

Your fresh experience. Peeling, cutting, slicing, shredding, mixing, blending, kneading, or whisking—no matter the preparation, Dito Sama ensures **perfect results in record time**. Enjoy optimal **ergonomics** for safer working conditions and certified hygiene, enabling you to offer your customers healthy, high-quality food. We are committed to delivering this unique experience through products built to last, combining **performance and reliability**.

Our values, your guarantee. Expertise, passion, and dependability - these pillars reflect our dedication as specialists in dynamic food preparation across all the markets we serve.



INDEX

	COMBINED CUTTER & VEGETABLE SLICERS	4
	VEGETABLE SLICERS	10
	FOOD PROCESSORS	22
	STICK BLENDERS & TURBOLIQUIDIZERS	30
	PLANETARY MIXERS	36
	VEGETABLE PEELERS	48
	VEGETABLE WASHERS AND SPIN DRYERS	52
	BREAD SLICER	54
	DOUGH KNEADERS	55
	DOUGH SHEETERS	56
	VACUUM PACKERS	58



Scan the QR code on the appliance and access all the contents that will make your daily life easier: user and maintenance manuals, videos and other support materials.



COMBINED CUTTER & VEGETABLE SLICERS

PREP4YOU

Fresh & healthy preparations made easy.
Vegetable slicer and cutter mixer, all in one

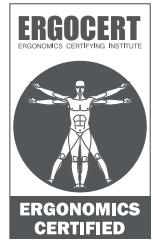

Consistent cutting results and maximized load capacity (1,25 lt.) thanks to the patented lever-pusher*



Large output chute for efficient ejection. Suitable for GN containers **up to 200 mm** high



100% dishwasher safe for best hygiene. All parts in contact with food are easy to remove for fast cleaning



Maximum flexibility: convert from slicer to cutter and reverse, in few seconds!



Bowl and lid scraper for **uniform results** and **continuous working**



All ingredients are processed evenly and quickly thanks to the special flow generated inside the bowl



- **End Users:** Restaurants / gastronomy / small catering / small educational and care facilities
- **From 10 to 100 settings**



Cutter Function:

- Chopping herbs and condiments, blending sauces, mincing meat/fish

Vegetable slicer function:

- Fresh-cut vegetables for sandwiches, salads and homemade fries



Moon hopper 1,25 lt capacity



- Compact and easy to move and store
- 2.6 lt stainless steel or BPA-free, transparent copolyester bowl or 3.6 lt stainless steel bowl available
- Micro-toothed blade rotor included
- Transparent lid equipped with scraper and central hole to add ingredients
- 1500 rpm or variable speed 500-3600 rpm
- Slicing, grating, shredding (julienne) as well as dicing and French fries cutting capability
- Continuous feed model: regular cuts, maximised load capacity (1,25lt) and less effort, thanks to the design patented lever-pusher
- 100% dishwasher safe: cutting chamber, lever hopper, ejector disc and stainless steel discs and grids
- Stainless steel cutting blades (diam. 175 mm) and aluminium discs for 8mm and 10 mm dicing to be combined with grids
- Slice, dice, grate, shred with a variety of 22 optional disks and grids in different sizes.
- Outstanding results even when dicing difficult vegetables such as tomatoes and onions



Small hopper Ø 55mm



Extra small hopper Ø 25mm

Discs:



Rotors:



Micro-toothed blade rotor (included as standard) for chopping, grinding, mixing and emulsifying



Smooth blade rotor available as optional, for clean cuts (for example meat tartare) and for delicate items like fresh herbs

PREP4YOU

Combined model with 2,6 lt bowl



Transparent copolyester or AISI304 stainless steel

PREP4YOU

Combined model with 3,6 lt bowl



AISI304 stainless steel

Speed	Phases	Power	rpm	Net weight
1 speed	1 ph	500 W	1500	15,8 kg*
Variable	1 ph	750W	500-3600	16.9 kg*
External dimensions (wxdxh): 348x328x527mm				

* stainless steel bowl

Speed	Phases	Power	rpm	Net weight
1 speed	1 ph	500 W	1500	16.1 kg*
Variable	1 ph	750W	500-3600	17.2 kg*
External dimensions (wxdxh): 348x334x527mm				

* stainless steel bowl



SLICING DISCS FOR **PREP4YOU**

Slicers - 1 mm to 10 mm



- 1 mm

- 2 mm

- 3 mm

- 4 mm

- 6 mm

- 8 mm

- 10 mm



Precision discs - 2 mm and 4 mm



- 2 mm

- 4 mm



Wavy slicers - 3 mm and 5 mm



- 3 mm

- 5 mm



Shredders - 2 mm to 8 mm



- 2 mm

- 4 mm

- 8 mm



Graters - 2 mm to 7 mm



- 2 mm
- 3 mm
- 4 mm
- 7 mm
- special disc for parmesan



Dicing grids* - 8x8 mm and 10x10 mm

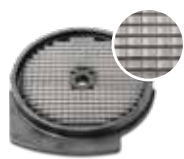

- 8x8 mm
- 10x10 mm

* to be combined with Slicers



Special tool for fast and easy cleaning of dicing grids
PNC 650110



Disc Holder
(disc not included)

ROTORS FOR PREP4YOU



Micro-toothed blade for 2,6 l. bowl



Micro-toothed blade for 3,6 l. bowl



Smooth blade for 2,6 l. bowl



Smooth blade for 3,6 l. bowl

Chop, mix, grind and emulsify with the micro-toothed blade rotor (included as standard)

Achieve clean cuts and perfectly chop delicate items such as fresh herbs and meat tartare with the smooth blade rotor (optional)



COMBINED CUTTER & VEGETABLE SLICERS TRK

3 in 1! With TRK, there are no limits to creative cooking. Three functions: vegetable slicer, cutter mixer, emulsifier. Three bowl sizes: 4.5, 5.5 and 7 litres. Variable speed from 300 to 880 rpm (slicer) and up to 3700 rpm (cutter).



Round, stainless steel hopper (215 cm²)



Long vegetable hopper (Ø 55 mm)

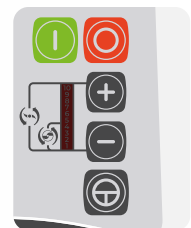

Flat waterproof control panel (IP55)



Transparent lid with scraper for better consistency

Switch safely and easily from cutter/emulsifier to veg prep function, thanks to the Incly system and the automatic speed limitation device



- **End Users:** Restaurants / Public Sector / Caterers / Nurseries / Residential Homes
- **From 50 to 400 covers**
Up to 800 covers for catering service



- **Cutter Function:**
- Coarse and fine chopping, emulsifying, kneading and mincing
- **Capacity** (e.g. mayonnaise):
TRK45: up to 2 kg
TRK55: up to 2,5 kg
TRK70: up to 3,5 kg

Vegetable slicer function:

- Wide range of cuts of fruits and vegetables for cold or hot preparations
- **Capacity:** up to 550 kg/h (depending on the cut)



Combined Cutter & Vegetable Slicer



- **Easy to change from a cutter to a vegetable slicer**
- **Transparent lid** equipped with scraper and central hole to add ingredients
- **Asynchronous industrial motor** for long life and silent operation
- Maximum speed up to **3700 rpm** (cutter function)
- Stainless steel bowl with high chimney to **increase** the real liquid **capacity**, with round corners and ergonomic handle
- **Dedicated rotors** with **smooth** or **microtoothed** blades as well as specific for **emulsions**
- **Large** and **long** vegetable **hoppers** integrated in the same design
- **Inclly System:** inclined motor base by 20° for better ejection of vegetables
- **Wide range** of **stainless steel discs** (205mm diameter) for more than 80 different cuts
- All parts in contact with food are **100% dishwasher safe** (vegetable and cutter attachments, rotors and discs)



TRK45 Combined Cutter & Vegetable Slicer 4,5 lt

Speed	Phases	Power	rpm
Variable	1 ph	1000 W	from 300 to 3700
External dimensions (WxDxH)			
Vegetable slicer 252x485x505mm			
Cutter 252x410x490mm			

TRK55 Combined Cutter & Vegetable Slicer 5,5 lt

Speed	Phases	Power	rpm
Variable	1 ph	1300 W	from 300 to 3700
External dimensions (WxDxH)			
Vegetable slicer 252x485x505mm			
Cutter 252x410x490mm			

TRK70 Combined Cutter & Vegetable Slicer 7 lt

Speed	Phases	Power	rpm
Variable	1 ph	1500 W	from 300 to 3700
External dimensions (WxDxH)			
Vegetable slicer 252x485x505mm			
Cutter 252x410x530mm			





VEGETABLE SLICERS

PREP4YOU

Fresh, healthy and homemade preparations made easy.
Space saving, fits even in the smallest kitchen.



Consistent cutting results thanks to the patented lever-pusher*



Full process control thanks to the transparent hopper



Maximised loading capacity up to **1.25 lt**

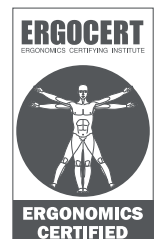

Large output chute for efficient ejection.
Suitable for GN containers **up to 200 mm high**



Pulse function for quick and precise cutting and grating.
Easy to clean motor base with flat control buttons

* Lever pusher applied for Patent EP19165854 and related family



- **End Users:** Restaurants / Quick Service
- **Up to 100 settings**



- **Main use:** optimal for restaurants, gastronomy and take-away, small educational facilities



- **Compact and easy to move and store**
- **Slicing, grating, shredding (julienne) as well as dicing and French fries cutting capability**
- Continuous feed model: regular cuts, maximised load capacity (1,25lt) and less effort, thanks to the design patented lever-pusher
- Equipped with half moon hopper and 2 small round feed chutes:
 - Ø 25mm and Ø 55mm, for precise slicing of long shaped vegetables
- **100% dishwasher safe:** cutting chamber, lever hopper, ejector disc and stainless steel discs and grids
- Stainless steel cutting blades (diam.175 mm) and aluminium discs for 8mm and 10mm dicing to be combined with (stainless steel/plastic) grids



Moon hopper 1,25 lt capacity



Small hopper Ø 55mm



Extra small hopper Ø 25mm

Slicers



Precision



Wavy slicers



Shredders



Graters



Parmesan grater



Dicing kits



more info on discs at page 6

Save up to 95% of your time avoiding manual preparations



Tomato

Cucumber

Celery root

Onion

Cabbage

Pizza cheese

Carrot



Disk

10x10x10 mm
dicing

2 mm
slicing

4 mm
shredding

8x8x8 mm
dicing

1 mm
slicing

7 mm
grating

3 mm
grating



Amount

2 kg

2kg

3 kg

5kg

3 kg

5kg

3 kg



Manual time

10' 37"

6' 45"

26' 05"

37' 58"

15' 06"

34' 31"

37' 04"

PREP4YOU time

26"

1' 19"

1' 27"

1' 39"

2' 34"

2' 45"

3' 37"

PREP4YOU Vegetable Slicer

Speed	Phases	Power	rpm	Net weight
1 speed	1 ph	500 W	1500	14 kg
Variable	1 ph	750 W	from 500 to 1200	15 kg
External dimensions (WxDxH): 348x315x527mm				



VEGETABLE SLICERS

TRS

Increased productivity, outstanding performance, superior quality and a sturdy design. Meets all your needs for preparing fruit and vegetables.



Round stainless-steel hopper (215 cm²)



Long vegetable hopper (Ø 55 mm)

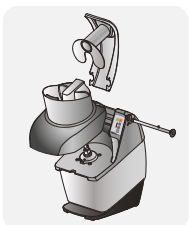

Easily dismantlable



Flat, waterproof control panel (IP55)



"Pulse" function for a precise cut



Stainless steel discs

100% dw safe: cutting chamber, stainless steel lever and hopper and all stainless steel discs and grids



- **End Users:** Restaurants / Small and Medium Size Catering Facilities / Caterers
- **100 to 400 covers** for table service
- Up to **800 covers** for catering service



- **Main use:** slicing, grating, wavy cuts, cutting into juliennes, french fries or dicing all kind of fruits and vegetables. Capacity: up to **500 kg/h**



Grate



Chips



Wavy slices



Cubes



- **Asynchronous industrial motor** for long life and silent operation
- **Ergonomic, easy to lift lever:** minimal pressure is required to process vegetables (for right or left hand use)
- **Maximum cleanability** due to the ergonomic design with rounded shapes.
- All parts in contact with food are **100% dishwasher safe**

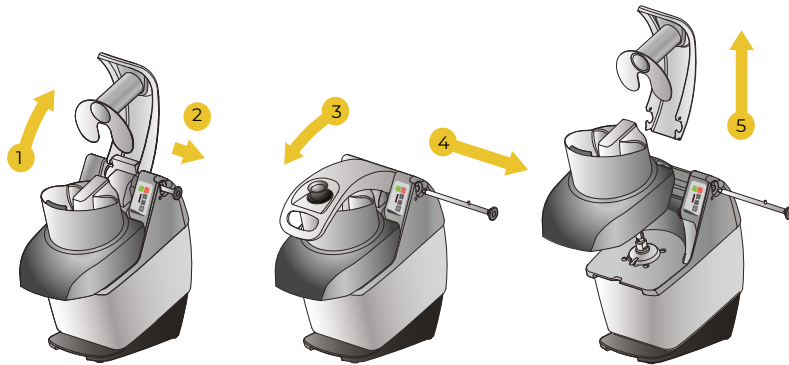

Stainless steel discs with holder included standard for a better organization in your kitchen

- **Wide range of stainless steel discs** (205mm diameter) for more than 80 different cuts
- **Inclined motor base** for better ejection of vegetables
- Easy access to the cutting chamber so the discs and ejector can be easily removed
- High discharge area for **deep GN containers** (up to 20 cm)

TRS Vegetable Slicer

Speed	Phases	Power	rpm
1 speed	1 ph	370 W	340
	1 ph	500 W	340
	3 ph	500 W	340
2 speeds	3 ph	750 W	340 / 680
Variable	1 ph	500 W	140 - 750

External dimensions (WxDxH): 348x315x527mm



High discharge area for deep GN containers



VEGETABLE SLICERS

TR210

With its automatic hopper, the TR210 cuts large quantities of fruit and vegetables. Optional hoppers provide the flexibility to tailor the machine to meet different requirements.



Stainless steel manual hopper (optional)



Stainless steel long vegetable hopper (optional)



Incluy System
20° angled base
(for use with manual
hopper)



Guaranteed
ergonomics and
flexibility with the
new stainless steel
trolley



- **End Users:** Small and medium catering facilities.
- **100 - 800 settings** for table service.
- **Up to 1000 settings** for catering service.



- **Main use:** slicing, grating, wavy cuts, cutting into juliennes, french fries or dicing all kind of fruits and vegetables.
Capacity: up to **2100 kg/h** (full speed and full load)



- **Asynchronous industrial motor** for long life and intensive use
- Model equipped with automatic hopper for high productivity especially for grating, slicing or dicing
- Removable cutting chamber : no food in contact with the motor base
- Continuous feeding model
- Table top or freestanding models, thanks to the ergonomic mobile trolley
- **100 % dishwasher safe:** cutting chamber, stainless steel lever, hoppers and discs



more info on discs at page 16

- **Wide range of stainless steel discs** (205mm diameter) for more than 80 different cuts
- **Unique and exclusive “S” shaped blades (patent pending)**
- Improved efficiency and versatility for slicing
- Superior slicing for precision cutting of hard and soft vegetables



TR210 Vegetable Slicer

Speed	Phases	Power	rpm
1 speed	1 ph	500 W	340
2 speeds	3 ph	750 W	340 / 680
variable	1 ph	500 W	140 - 750

External dimensions (WxDxH): 252x485x505mm



SLICING DISCS FOR TRS / TR210 / TRK

Graters - 2 mm to 9 mm



2 mm

3 mm

4 mm

7 mm*

9 mm*

for breadcrumbs / potatoes

for parmesan / chocolate

*7 and 9 mm discs are suitable to grate mozzarella and semi-dry cheese



Shredders - 2 mm to 10 mm



2x2 mm

3x3 mm

4x4 mm

6x6 mm

8x8 mm

10x10 mm

2x8 mm

2x10 mm



Slicers - 0.6 mm to 13 mm



- 0.6 mm
- 1 mm
- 2 mm
- 3 mm
- 4 mm
- 5 mm
- 6 mm
- 8 mm
- 10 mm
- 12 mm
- 13 mm



Wavy slicers - 2 mm to 10 mm



- 2 mm
- 3 mm
- 6 mm
- 8 mm
- 10 mm



Dicing grids* - 5x5 mm to 20x20 mm



- 5x5x5 mm
- 8x8x8 mm
- 10x10x10 mm
- 12x12x12 mm
- 13x20x20 mm



Grids for chips* - 6, 8 and 10 mm



- 6x6 mm
- 8x8 mm
- 10x10 mm



* to be combined with Slicers and Wavy slicers



VEGETABLE SLICERS

TR260

Equipped with a wide range of accessories, the TR260 will be your partner for the success of your largest culinary events

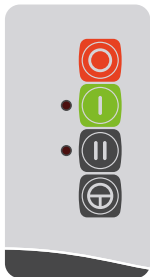

Flat and waterproof control panel (IP55)



Automatic feed hopper (optional).
Up to 6 kg of vegetables



Stainless steel mobile stand.
Disc rack (optional)



- **End Users:** Public Sector / Small Food Industries / Central Kitchens
- **400 to 600 covers** for table service
Up to **2000 covers** for catering service



- **Main use:** slicing, grating and cutting all kind of fruits and vegetables
- Capacity: up to **2500 kg/h** (with automatic hopper)
- Capacity: approx. **700 kg/h** (with lever hopper)



- **High productivity** guaranteed with 300 mm diameter discs
- Automatic hopper for **continuous operation** and productivity
- **Asynchronous industrial motor** for long life and silent operation
- User friendly **waterproof control** panel with **pulse function** and speed selector (only on 2 speed models) for **precise slicing**
- **Maximum versatility.** Combine motor base with a variety of optional accessories to suit your needs



Lever operated hopper



Long vegetable accessory for lever operated hopper



Long vegetables hopper with 3 tubes (Ø 50 to 70mm)



Cabbage hopper to cut an entire cabbage (max. Ø 250 mm). To be combined with cabbage discs



Wide selection of discs (Ø 300 mm)



Stainless steel trolley for 2/1 GN containers

TR260 Vegetable Slicer

Speed	Phases	Power	rpm
1 speed	1 ph	1500 W	330
2 speeds	3 ph	2000 W	330 / 660

External dimensions (WxDxH): 750x380x460mm



POTATO CHIPPER

RC14

High output potato chipper for use in large catering kitchens and specialized chip production.



Stainless steel mobile stand (optional accessory)



Automatic hopper with a capacity up to 1.500 kg/h (25 kg/min.)



Chipping block (optional accessory)



French fries cutting block (optional accessory)

The RC14 is designed for intensive use and ensures a high level of safety to the operator.



- **End Users:** Central kitchens / specialized chip production / theme restaurants



- **Main use:** slicing and french fries cuts
- Capacity: up to **1500 kg/h**



- **Asynchronous industrial motor** for long life and silent operation
- Specific table top machine for potatoes with automatic hopper
- Compact and easy to clean
- Chipping or french fries cutting blocks available in different sizes
- Easy access to the cutting chamber to insert the cutting block
- Hopper, cutting block and rotor easily removable for cleaning (see picture on the right)



French fries



8x8 mm



10x10 mm



12x12 mm



14x14 mm



Chipping



4 mm



6 mm



8 mm



Shape and cutting consistency granted by the Dito Sama special rotor which directs properly potatoes towards the cutting block.



FOOD PROCESSORS

PREP4YOU

Fresh, healthy and home made preparations made easy.
Chop, mix, grind and emulsify to perfection.



Bowl and lid scraper for **uniform results** and **continuous working**



All ingredients are **processed evenly and quickly** thanks to the special flow generated inside the bowl



100% dishwasher safe for best hygiene. All parts in contact with food are easy to remove for fast cleaning

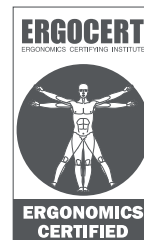

Time saving: lid with funnel shaped hole to add ingredients during use



Full control thanks to the **transparent lid**



Intuitive control panel with easy to clean, flat and soft-touch buttons



- **End Users:** Restaurants / Gastronomy / Elderly homes
- **From 10 to 50 settings**



- **Main use:** chopping herbs and condiments, blending sauces, mincing meat/fish, grinding



- **Compact and easy to move and to store**
- 2,6 lt stainless steel or BPA-free transparent copolyester bowl or 3,6lt stainless steel bowl available
- Micro-toothed blade rotor included
- Transparent lid equipped with scraper and central hole to add ingredients for continuous working
- **100% dishwasher safe: all parts in contact with food are easy to remove for fast cleaning**
- 1 speed 1500 rpm or variable speed 500-3600 rpm for smoother results and best emulsifying



- **Smooth blade rotor** available as optional, for clean cuts (for example meat tartare) and for delicate items like fresh herbs



- **Micro-toothed blade rotor** (included as standard) for chopping, grinding, mixing and emulsifying

PREP4YOU

Cutter mixer with 2,6 lt bowl



Transparent copolyester or AISI304 stainless steel

Speed	Phases	Power	rpm	Net weight
1 speed	1 ph	500 W	1500	13 kg*
Variable	1 ph	750W	500-3600	14 kg*
External dimensions (wxdxh): 247x328x456mm				

* stainless steel bowl

PREP4YOU

Cutter mixer with 3,6 lt bowl



AISI304 stainless steel

Speed	Phases	Power	rpm	Net weight
1 speed	1 ph	500 W	1500	13 kg*
Variable	1 ph	750W	500-3600	14.5 kg*
External dimensions (wxdxh): 252x334x476mm				

* stainless steel bowl



FOOD PROCESSORS

K45 / K55 / K70

High-power food processors are built to last and can chop, mince, grind and blend any preparation required by your recipes.

Up to
3 700 rpm



Transparent lid with scraper for better consistency



High chimney to increase the real liquid capacity



K55

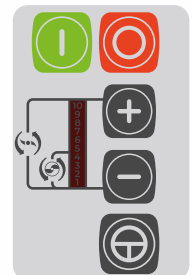

Flat waterproof control panel (IP55)



"Pulse" function for coarse chopping of large pieces

**2 in 1 machine, thanks to the scraper:
consistent results in a matter of seconds.**



- **End Users:** Restaurants / Catering Facilities / Caterers / Nurseries and Residential Homes
- From **50 to 150 covers**



- **Main use:** Coarse and fine chopping, emulsifying, kneading and mincing



- **Stainless steel bowl: 4,5 / 5,5 / 7 lt**
- Capacity (e.g. mayonnaise):
K45: up to **2 kg**
K55: up to **2,5 kg**
K70: up to **3,5 kg**
- Speed: **from 300 to 3700 rpm** (see models)
- **Asynchronous industrial motor** for long life and silent operation
- Transparent and **dismountable lid attached to the body**
- **Delivered with scraper/emulsifier**
- **Dedicated rotors** with smooth or microtoothed blades as well as specific for emulsions
- All parts in contact with food can be **easily disassembled** without tools and are **100% dishwasher safe**



Holder for rotor included

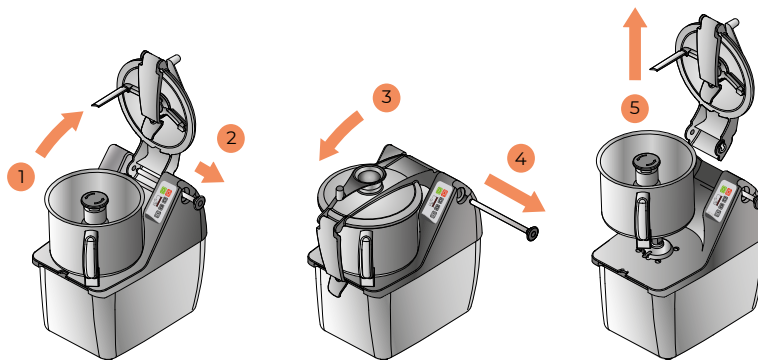

K45 Cutter 4,5 lt capacity

Speed	Phases	Power	rpm
1 speed	1 ph	750 W	1500
2 speeds	3 ph	900 W	1550 / 3000
Variable	1 ph	1000 W	from 300 to 3700
External dimensions (WxDxH): 252x410x490mm			



Ground meat

K55 Cutter 5,5 lt capacity

Speed	Phases	Power	rpm
2 speeds	3 ph	1000 W	1550 / 3000
Variable	1 ph	1300 W	from 300 to 3700
External dimensions (WxDxH): 252x410x490mm			



Vegetable purées

K70 Cutter 7 lt capacity

Speed	Phases	Power	rpm
Variable	1 ph	1500 W	from 300 to 3700
External dimensions (WxDxH): 252x410x530mm			



FOOD PROCESSORS

K120S / K180S

Mix and mince quickly and easily, while preserving the texture and flavour of your ingredients



Stainless steel bowl with leak-proof spout



Safety double lock system



K180S



Flat and waterproof control panel (IP55)



Exclusive angled-blade design ensures consistent, optimal mixing results



- **End Users:** Restaurants / Caterers / Delicatessen
- From **100 to 300 covers**



- **Main use:** coarse and fine chopping, emulsifying, kneading and mincing



- **17,5 lt capacity** stainless steel bowl
- 2 speeds: **1500 and 3000 rpm** (K180S)
- Variable speed available: **from 300 to 3000 rpm** (KE180S)
- Capacity: up to **8 kg** (e.g. mayonnaise)



- **End Users:** Restaurants / Caterers / Delicatessen / Catering Facilities
- From **100 to 200 covers**



- **Main use:** coarse and fine chopping, emulsifying, kneading and mincing



- **11,5 lt capacity** stainless steel bowls
- 2 speeds: **1500 and 3000 rpm** (K120S)
- Variable speed available: **from 300 to 3500 rpm** (KE120S)
- Capacity: up to **6 kg** (e.g. mayonnaise)



K120S

Features for all models:

- “Pulse” function for a coarse chopping of large pieces (on 2 speed models)
- Rotor and bowl design ensure **consistent mixing**
- **Asynchronous industrial motor** for long life and silent operation
- Transparent lid, bowl, scraper and rotor can be **easily removed without tools** and are **100% dishwasher safe**
- **Bowl scraper for consistent results**
- **3 devices to ensure operator safety** (K/KE 120S/180S):
 - 1 hinge sensor when handle is lifted
 - 1 bowl presence sensor
 - 1 cover presence sensor



Bowl scraper

K120S/KE120S Cutter 11,5 lt capacity

Model	Speed	Phases	Power	rpm
K120S	2 speeds	3 ph	2200 W	1500 / 3000
KE120S	variable	1 ph	2200 W	300 to 3500

External dimensions (WxDxH): 416x680x517mm

K180S/KE180S Cutter 17,5 lt capacity

Model	Speed	Phases	Power	rpm
K180S	2 speeds	3 ph	3600 W	1500 / 3000
KE180S	variable	1 ph	3600 W	300 to 3500

External dimensions (WxDxH): 416x680x603mm





ROTORS K AND TRK

Choose the perfect cutting blade for your preparation



Smooth rotor blade



Microtoothed rotor blade
(included as standard)



Microtoothed emulsifier blade



Ground meat



Almonds



Asparagus



Houmous



Chocolate



Peppers



Tomato sauce



Mixed herbs



Chicken

Texture-modified food with K and TRK

High-speed, integrated bowl scraper and exclusive blade design. These three features help turn your food processor into an emulsifier that allows you to modify the texture of food while preserving its nutritional content and taste. The only limit is your imagination!



Microtoothed emulsifier blade
K45/55/70



Pasta



Poultry



Fish



Cake



Sausage



Salmon





STICK BLENDERS

Bermixer PRO

Wide range from 350 W to 750 W. Prepare soups, purees, sauces and creams, and whip egg whites quickly and easily



Dismountable without tools and dishwasher safe



Durability guaranteed thanks to the easily removable blade that can be sharpened or replaced

less than
4 kg



9 speed levels automatic power adjustment

**Up to
10 000 rpm**



Safe handling thanks to the heat protected grip



- **End Users:** Restaurants / Catering Facilities
- From **50 to 300 covers**



- **Main use:** soups, purées, sauces, creams



- Light and easy to use stick blender
- **Smart Speed Control:** autoregulation of the power to ensure a longer life and reduced vibrations
- Vortex system to process the entire preparation, no need to stir
- Control panel with **overload indicator alarm**
- Special lipped design of the blade protection **avoids splashing** aligned with the strictest regulations in terms of safety
- All parts in contact with food are **easily disassembled and 100% dishwasher safe**
- Thermal insulated plastic insert on the tube

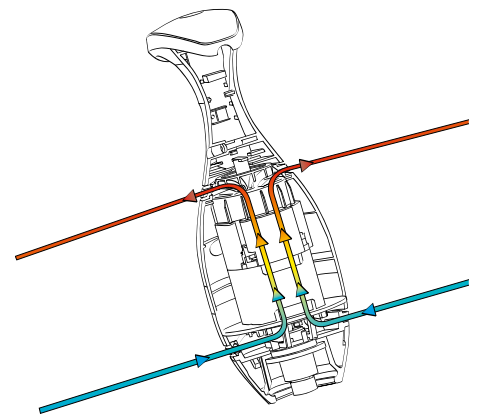

Air cooling system for longer usage without overheating

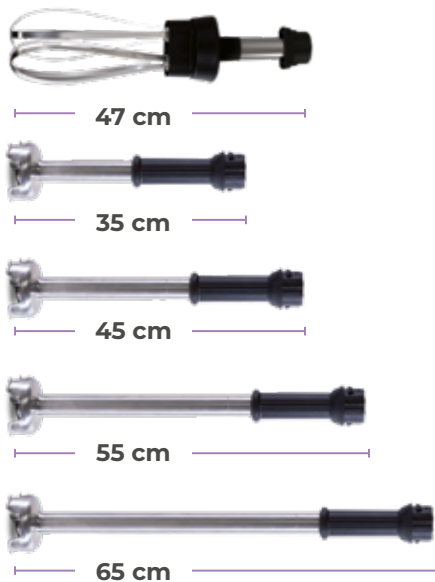

Pot holder



Supplied with wall support



Dismountable blade



Quick and easy disassembly of axe **without tools**



STICK BLENDERS

Speedy Mixer

MS200 and MS250. Dynamic tools for your busy kitchen to prepare soups and creams in small quantities. Easy to use and space saving.



Dismountable without tools

15 000 UpM



Emulsifier tube available



Ergonomic handle



Stainless steel bell, blade and tube



- **End Users:** Restaurants / Catering Facilities
- From **50 to 300 covers**



- **Main use:** soups, purées, sauces, creams



- Light and easy to use stick blender
- Available with 20 or 25 cm stainless steel tube
- Ideal for small quantities
- Optional whisk available for the variable speed models
- Emulsifier tube available
- Available with variable speed
- Thanks to the easy tool junctions, the motor unit and tube can be **disassembled without tools for cleaning**

A complete range



SPEEDY MIXER

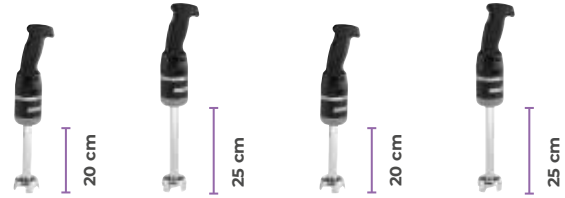

Models	MS200 (DSMT20W25)	MS250 (DSMT25W25)	MS200VV (DSMVT20W25)	MS250VV (DSMVT25W25)
Power	250 W		250 W variable speed	
Tube	20 cm	25 cm	20 cm	25 cm
Weight	1,4 kg	1,45 kg	1,4 kg	1,45 kg
Max. capacity	Ideal for small quantities			

BERMIXER PRO 9 000 rpm

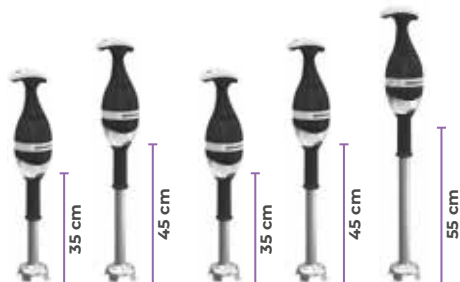

BERMIXER PRO Turbo 10 000 rpm



Models	DBP3535	DBP3545	DBP4535	DBP4545	DBP4555	DBP5545	DBP5555	DBP6545	DBP6555	DBP6565	DBP7555	DBP7565
Power	350 W		450 W			550 W		650 W		750 W		
Tube	35 cm	45 cm	35 cm	45 cm	55 cm	45 cm	55 cm	45 cm	55 cm	65 cm	55 cm	65 cm
Max. capacity	30 l	50 l	80 l	100 l	120 l	150 l	170 l	200 l	220 l	240 l	270 l	290 l





TURBOLIQUIDIZERS

TBX PRO - TBM 150

The best appliances to mix, blend, liquefy and emulsify a wide variety of preparations thanks to specific tools.

Stainless steel tubes and tools, easily removable and dishwasher safe*, ensure optimal hygiene.



Mounted on a stainless steel trolley for easier movement and storage in the kitchen

TBX PRO
up to 700 liters

TBM 150
up to 1000 liters



- **End Users:** Central kitchens / large caterers / hospitals / care homes / large schools / universities / staff canteens
- **From smallest quantities** (min immersion depth 140mm with deflector tube) **up to 700 liters or 350 Kg** thick preparations like mashed potatoes



- **Main use:** soups, purées, sauces, liquid dough



- Floor standing mixer mounted on a stainless steel trolley with braked wheels
- Easily convert from the mixing tool to the purée tool
- **Ergonomic** and easy to use, adapts quickly and effortlessly to different pots heights/depths
- Can be used in braising pans and boiling pans up to 700 liters
- **Waterproof control panel**
- Stainless steel mixing tube and accessories can be disassembled without tools and are **100% dishwasher safe** (TBX Pro, except ball bearing)
- **Asynchronous industrial motor** for long life and silent operation



Turboliquidizers

Model	Speed	rpm/min	Power	Dimensions (WxDxH)	Food consistency
TBX Pro	1 speed	1600	1500 W	628x1556x1122 mm	for liquids (soups, liquid dough)
TBX Pro	2 speeds	850/1700	2200 W	628x1556x1122 mm	for liquids/semiliquids, mixing powders
TBX Pro	variable speed (1 or 3-phase)	from 630 to 1700	1500 W	628x1556x1122 mm	for liquids and thick food (purée)
TBM150	1 speed	1650	3000 W	664x1852x1475 mm	for liquids, up to 1000 lt
TBM150	2 speeds	830/1600	4500 W	664x1852x1475 mm	for liquids and purée/thick consistency

Optional accessories for TBX Pro

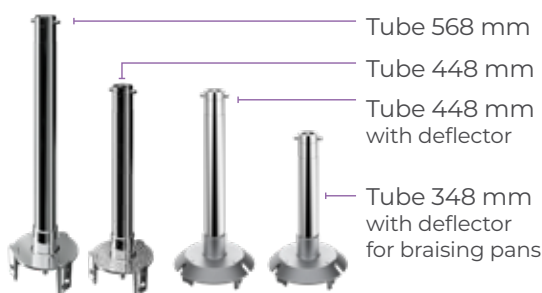

Soup tool for boiling pans



Purée tool for boiling pans



Soup grid Ø 6-8mm (included in soup tool)



Soup grid Ø 8-10 mm



Soup grid Ø 19 mm



Soup tool for braising pans



Purée tool for braising pans



PLANETARY MIXERS

BE5 / BE8

More than 50 years experience in the innovation and design of planetary mixers brought together in a unique and compact model.



BE5

BE8



- **End Users:** Restaurants/ Catering Facilities / Pastry Making
- From **10 to 50 covers**



- **Main use:** kneading, emulsifying and whisking



- **5 and 8 lt capacities**
- Powerful asynchronous motor with frequency variator for a precise adjustment of the speed of planetary mechanism **from 20 to 220 rpm**
- Variable speed rotation of the tools from **67 to 740 rpm**

- Tools designed for full coverage of the bowl for uniform mixing of even small quantities
- **100% stainless steel** tools and stainless steel bowl
- **Bowl detection device** which will allow the mixer to switch on only when the bowl is properly positioned with the safety screen*.

* UNI EN 454:2015 Food Processing Machinery - Planetary Mixers - Safety And Hygiene Requirements. This European Standard specifies safety and hygiene requirements for the design and manufacture of fixed bowl planetary mixers with a tool having a planetary movement by using two parallel axes. The capacity of the bowl is greater than or equal to 5 L and less than or equal to 200 L.

Highly resistant splash guard - BPA free

Maximum reliability guaranteed.

- Maximum reliability guaranteed. Transparent screen made from Eastman Tritan™ copolyester* (BPA-free). Impact resistant: stays clear and durable even after hundreds of washes.

* Eastman and Tritan are trademarks of Eastman Chemical Company

- New screwless **clip** system facilitates **easy removal** of the guard for cleaning
- Innovative shape for **easily adding ingredients** during operation



Simple movement of splash guard for fitting and removing the bowl



"Clip" system for easy removal



Reinforced splash guard



Ergonomic knob

- Variable speed planetary mechanism adjusted using an ergonomic knob (20–220 rpm)
- Sturdy metal **accessory hub** able to withstand heavy usage
- Optional accessories: meat mincer and pasta kit (for accessory hub models)



Accessory hub (on selected models)



3 tools for 100% performance

- **100% quality**
stainless steel tools
- **100% resistant**
for intensive use and longer life
- **100% hygiene**
dishwasher safe (tools, bowl and splash guard)



	Hook		Paddle		Whisk	
	Flour*		Potato purée		Whipped egg whites	
	Min.	Max	Min.	Max	Min.	Max
BE5	100 g	1,5 kg	100 g	2 kg	1	10/12
BE8	120 g	2,5 kg	100 g	3,2 kg	1	14/16

* For dough with 60% moisture content



PLANETARY MIXERS

10 / 20 lt table top



XBE10



**XBM 20
table top**



- **End Users:** Restaurants/ Catering Facilities / Pastry Making
- From **10 to 100 covers (10 lt)** and **from 50 to 150 covers (20 lt)**



- **Main use:** kneading, emulsifying and whisking



- **Bowl detection device** which will allow the mixer to switch on only when the bowl is properly positioned with the safety screen*.

* UNI EN 454:2015 Food Processing Machinery - Planetary Mixers - Safety And Hygiene Requirements. This European Standard specifies safety and hygiene requirements for the design and manufacture of fixed bowl planetary mixers with a tool having a planetary movement by using two parallel axes. The capacity of the bowl is greater than or equal to 5 L and less than or equal to 200 L.

10 lt table top model

- Powerful asynchronous motor for **silent operation** and **longer life**
- Models with electronic or mechanical speed variation from 26 to 180 rpm
- Removable safety screen associated with the raising and lowering of the bowl
- Tool speed rotation: 82 to 570 rpm
- Splash proof planetary system
- Models available with **accessory hub** (type H)
- Stainless steel column
- Capacity (kg flour): **3,5 kg**



The solid safety screen and the stainless steel wire structure are both removable and disassembled for cleaning and are dishwasher safe (20 lt)



Stainless steel column and feet (10 lt)



Flat and waterproof control panel (IP55) with timer 0-59 minutes



Bowl, hook, paddle, whisk specifically designed for the most efficient result. Mixer starts only when the bowl is in position

20 lt table top model

- Powerful asynchronous motor for **silent operation** and **longer life**
- Models with electronic or mechanical speed variation
- Speed of planetary mechanism: from **30 to 180 rpm** (see models)
- Tool speed rotation: 73 to 440 rpm
- Splash proof planetary system
- 10 lt bowl reduction kit available
- Models available with **accessory hub** (type H)
- Capacity (kg flour): **6 kg**
- **Blind/solid safety screen** which will limit flour and unsafe dust particles when used in bakery and pastry preparation.



Removable spout to add ingredient during process



Mechanical versions with 8 speed levels



PLANETARY MIXERS

20 / 30 lt freestanding



XBE20



XBM30



- **End Users:** Restaurants / Catering Facilities / Pastry Making
- From **50 to 150 covers (20 lt)** and **from 100 to 300 covers (30 lt)**



- **Main use:** kneading, emulsifying and whisking



- **Bowl detection device** which will allow the mixer to switch on only when the bowl is properly positioned with the safety screen*.

* UNI EN 454:2015 Food Processing Machinery - Planetary Mixers - Safety And Hygiene Requirements. This European Standard specifies safety and hygiene requirements for the design and manufacture of fixed bowl planetary mixers with a tool having a planetary movement by using two parallel axes. The capacity of the bowl is greater than or equal to 5 L and less than or equal to 200 L.

20 lt freestanding models

- Powerful asynchronous motor for **silent operation** and **longer life**
- Models with electronic or mechanical speed variation
- Speed of planetary mechanism: from **30 to 180 rpm** (see models)
- Tool speed rotation: 85 to 440 rpm
- Splash proof planetary system
- Models available with **accessory hub** (type H)
- 10 lt bowl reduction kit available
- Optional wheel kit
- Capacity (kg flour): **6 kg**
- **Blind/solid safety screen** which will limit flour and unsafe dust particles when used in bakery and pastry preparation.



The solid safety screen and the stainless steel wire structure are both removable and disassembled for cleaning and are dishwasher safe (20, 30 lt)



Bowl, hook, paddle, whisk specifically designed for the most efficient result. Mixer starts only when the bowl is in position



Flat and waterproof control panel (IP55) with timer 0-59 minutes



Stainless steel column and feet (on request)

30 lt freestanding models

- Powerful asynchronous motor for **silent operation** and **longer life**
- Models with electronic or mechanical speed variation
- Speed of planetary mechanism: from **30 to 180 rpm** (see models)
- Tool speed rotation: 73 to 440 rpm
- Splash proof planetary system
- Models available with **accessory hub** (type H)
- 20 lt bowl reduction kit available
- Optional wheel kit
- Capacity (kg flour): **7 kg**
- **Blind/solid safety screen** which will limit flour and unsafe dust particles when used in bakery and pastry preparation.





PLANETARY MIXERS

40 / 60 / 80 lt freestanding



MBE40



BMX60AS



BMXE80



- **End Users:** Restaurants / Catering Facilities Central kitchens / Bakery and Pastry
- From **100 to 400 covers (40 lt),**
from 400 to 800 covers (60/80 lt)



- **Main use:** kneading, emulsifying and whisking



- **Bowl detection device** which will allow the mixer to switch on only when the bowl is properly positioned with the safety screen*.

* UNI EN 454:2015 Food Processing Machinery - Planetary Mixers - Safety And Hygiene Requirements. This European Standard specifies safety and hygiene requirements for the design and manufacture of fixed bowl planetary mixers with a tool having a planetary movement by using two parallel axes. The capacity of the bowl is greater than or equal to 5 L and less than or equal to 200 L.

40 lt freestanding models

- Powerful asynchronous motor for **silent operation** and **longer life**
- Electronic variable speed and 3 fixed speeds (see models)
- Flat waterproof control panel equipped with timer
- Speed of planetary mechanism: from **30 to 175 rpm** (see models)
- Tool speed rotation: from 94 to 540 rpm (see models)
- Splash proof planetary system
- Models available with **accessory hub** (type H)
- 20 lt bowl reduction kit available
- Optional wheel kit
- Capacity (kg flour): **10 kg**
- **Blind/solid safety screen** which will limit flour and unsafe dust particles when used in bakery and pastry preparation.



The solid safety screen and the stainless steel wire structure are both removable and disassembled for cleaning and are dishwasher safe (40 lt)



Bowl, hook, paddle, whisk specifically designed for the most efficient result. Mixer starts only when the bowl is in position



Bowl scraper



Feet and column reinforced for heavy duty. Stainless steel frame (on selected models)

60 and 80 lt freestanding models

- **60 and 80 lt** capacity
- Powerful asynchronous motor for **silent operation** and **longer life**
- Models with **mechanical, electrical or electronic speed variation**
- Speed of planetary mechanism: from **20 to 180 rpm**
- Tool speed rotation: 62 to 560 rpm
- Splash proof planetary system
- Motorized bowl movement (on specific models)
- Models available with **accessory hub** (type H)
- **40 or 60 lt** bowl reduction kit available
- Bowl trolley with wheels and bumper facilitates bowl movement (standard on 80 lt)
- Capacity (kg flour): **20 kg** (60 lt) / **25 kg** (80 lt)
- **Blind/solid safety screen** which will limit flour and unsafe dust particles when used in bakery and pastry preparation.



Bowl lighting



PLANETARY MIXERS

Bakery, Pastry and Pizza

Planetary mixers designed for intensive and professional bakery, pastry and pizza applications, with dedicated models 20, 30 and 40 lt capacities.

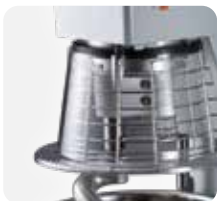

The solid safety screen and the stainless steel wire structure are both removable and disassembled for cleaning and are dishwasher safe (20, 30, 40 lt)



Bowl, hook, paddle, whisk specifically designed for the most efficient result. Mixer starts only when the bowl is in position



Control panel with timer, electronic variable speed and 3 fixed speeds



Feet and column reinforced for heavy duty



- **End Users:** Bakery / Pastry / Pizza preparations



- **Main use:** kneading, mixing, whipping and emulsifying



- **Bowl detection device** which will allow the mixer to switch on only when the bowl is properly positioned with the safety screen*.

* UNI EN 454:2015 Food Processing Machinery - Planetary Mixers - Safety And Hygiene Requirements. This European Standard specifies safety and hygiene requirements for the design and manufacture of fixed bowl planetary mixers with a tool having a planetary movement by using two parallel axes. The capacity of the bowl is greater than or equal to 5 L and less than or equal to 200 L.

20 and 30 It models

- Powerful asynchronous motor (1500 W) for **silent operation** and **longer life**
- Speeds: **3 fixed speeds (40, 80, 160 rpm)** and electronic variable speed from 30 to 175 rpm
- Tools speed: from 73 to 425 rpm
- Reinforced structure and transmission
- Splash proof planetary system
- Control panel equipped with 0-59 minute timer
- Stainless steel **removable** rotating **safety screen**, equipped with removable spout
- Lever for raising and lowering the bowl
- Wheel kit and bowl trolley (optional)



XBB30



Bowl scraper



Bowl trolley



Spiral hook, paddle and reinforced whisk

40 It models

- Powerful asynchronous motor (2200 W) for **silent operation** and **longer life**
- MB40: 3 fixed speeds (40, 80, 160 rpm)
- MBE40: 3 fixed speeds (40, 80, 160 rpm) and electronic variable speed (30 to 175 rpm)
- Tools speed: 125, 250 and 500 rpm (MB40), from 94 to 540 rpm (MBE40)
- Reinforced structure and transmission
- **20 It** bowl reduction kit available
- Splash proof planetary system
- Bowl trolley (optional)
- **Blind/solid safety screen** which will limit flour and unsafe dust particles when used in bakery and pastry preparation.





PLANETARY MIXERS

make the right choice

Kitchen equipment - electronic variation



model	BE5	BE8	XBE10	XBE20	XBE30	MBE40	XBE60	XBE80
capacity	5 lt	8 lt	10 lt	20 lt	30 lt	40 lt	60 lt	80 lt
hook*	1,5 kg	2,5 kg	3,5 kg	6 kg	7 kg	10 kg	20 kg	25 kg
whisk*	10	14	18	32	50	70	100	120

Bakery, pastry and pizza



model	BE5	BE8	XBB20	XBB30	MBE40	XBE60	XBE80
capacity	5 lt	8 lt	20 lt	30 lt	40 lt	60 lt	80 lt
hook*	1,5 kg	2,5 kg	7 kg	8 kg	10 kg	20 kg	25 kg
whisk*	10	14	32	50	70	100	120

*Hook: kg of flour for dough (with 60% moisture content)

*Whisk: max. number of egg whites

Accessories

Choose the perfect accessory for your preparation



Vegetable slicer



Meat mincer



Purée strainer

Meat mincer for attachment hub type H.
Simply choose the external support and combine it with any of the mincing kits for maximum flexibility

MMH70



653720

External support in aluminum 70 mm. Delivered with tray and pusher

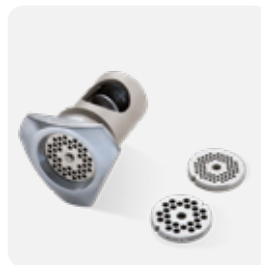

653721

Enterprise aluminum (knife & discs in s/s)

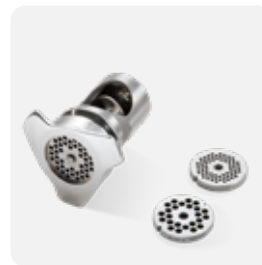

653722

Enterprise all in s/s



653723

½ Unger all in s/s

MMH82 (recommended for >40 lt planetary mixers)



653724

External support in aluminum 82 mm. Delivered with tray and pusher



653726

Enterprise aluminum (knife & discs in s/s)

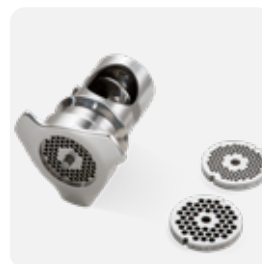

653725

Enterprise all in s/s



653727

½ Unger all in s/s



VEGETABLE PEELERS

T Series

Multi-purpose machines. The ideal solutions for peeling, washing, cleaning and drying vegetables and shellfish.



Transparent lid with removable spray gun



Removable bowl for easy unloading and cleaning



T5E/T8E
table top



Integrated filter (depending on model)



Drying basket (optional)



- **End Users:** Restaurants / Catering Facilities
- From **50 to 300 covers**



- **Main use:** vegetable peeling and seashell cleaning



- **5 kg** or **8 kg** capacity per operation
- Maximum output: **80 kg/h** (T5E) and **130 kg/h** (T8E)



- Removable rotating plate covered with an abrasive material that guarantees **durability** and **longer life**
- Plate speed rotation: **300 rpm**
- Specific models available for **cleaning shellfish** (T5M/T8M) with a reduced speed (208 rpm), seashell plate and cylinder
- **Asynchronous industrial motor** for long life and silent operation

T5S



- **End Users:** Restaurants / Catering Facilities
- From **50 to 300 covers**



- **Main use:** vegetable peeling



- **5 kg** or **8 kg** capacity per operation
- Maximum output: **80 kg/h** (T5E) and **130 kg/h** (T8E)
- Removable rotating plate covered with an abrasive material that guarantees **durability** and **longer life**
- Plate speed rotation: **350 rpm**
- **Knife plate** (for a smooth cut of the peel), **washing plate** (for cleaning vegetables that don't require peeling) and stainless steel **filter table** available upon request
- **Safety:** the motor stops if the lid or door is opened during operation
- **Asynchronous industrial motor** for long life



Transparent and removable lid



Ergonomic handle



Timer



Knife plate (optional)





VEGETABLE PEELERS

T Series



Abrasive plate and cylinder



Knife plate



Flat and waterproof control panel with programmable timer (IP55)



Large opening for easy unloading

T10E/T15E



- **End Users:** Restaurants / Catering Facilities / Caterers
- From **50 to 300 covers**



- **Main use:** vegetable peeling, scrubbing, washing and spinning



- **T10E:** **10 kg** capacity per operation
Maximum output: **160 kg/hr**
- **T15E:** **15 kg** capacity per operation
Maximum output: **240 kg/hr**



- Stainless steel construction
- Plate speed rotation: **300 rpm**
- Removable rotating plate covered with an abrasive material that guarantees **durability** and **longer life**
- More flexibility with optional plates (knife plate, onion plates, garlic/shallot plate, mussel cleaner, brushing plate and drying basket)
- **Safety:** the motor stops if the lid or door is opened during operation
- **Asynchronous industrial motor** for long life and silent operation

T25



- End Users: Restaurants / Central Kitchens / Catering Facilities / Caterers
- **From 100 to 500 covers**



- **Main use:** peeling all types of hard skinned vegetables (celery, potatoes, carrots)



- **25 kg** capacity per operation
- Maximum output: more than **400 kg/h**
- Plate speed rotation: **300 rpm**
- The cylinder and removable rotating plate are covered with an abrasive material that guarantees **durability** and **longer life**
- Stainless steel construction
- Door with constant pressure control system for the **safe unloading** of the **vegetables**
- **Safety:** the motor stops if the lid or door is opened during operation
- Flat and **waterproof** control **panel** (IP55)
- **Asynchronous industrial motor** for long life and silent operation



Drain hole



Unloading door



T25E



Ti25

Possibility to choose the direction of the evacuation of peelings

Integrated filter basket as standard

T series Peilers

Model	Capacity	Dimensions (WxDxH)	Notes
T5S	5 kg	314x485x450 mm	
T5E/T5M	5 kg	424x390x590 mm	special model for seashells
T8E/T8M	8 kg	422x396x676 mm	special model for seashells
T10E	10 kg	440x690x680 mm	
T15E	15 kg	440x690x750 mm	
T25E	25 kg	585x785x1215 mm	
Ti25	25 kg	565x880x1425 mm	inclined body



VEGETABLE WASHERS AND SPIN DRYERS

A great choice for all kitchen sizes.



LVA100



- **End Users:** Restaurants / Catering facilities
- Up to **200 covers**



- **Mainly use:** Washing and drying leafy vegetables (salad, cabbage, fennel) and herbs (basil, parsley)





- **Load per cycle**
 - light vegetables: 2-3 kg
 - heavy vegetables: 12-15 kg
 - 3 automatic washing cycles, with or without sanitation, 2 pump speeds, option to exclude spinning



- Automatic or manual draining function
- **Avoid damage to delicate** items by regulating the washing intensity
- **Space saving: washing and drying in one appliance**
- Manual operating mode: set time and pump speed with possibility to exclude spinning (i.e. heavy vegetables)
- Continuous cycle available
- **3 automatic washing cycles** with possibility to include sanitizing agent
- **Cleanability:** self-cleaning cycle and water sprayer included to remove residues



EL40

- 
End Users: Restaurants / Catering Facilities
 - From 100 to 300 covers**
- 
Main use: Spinning of all vegetables and herbs, lettuce, spinach, parsley, leeks
- 
 - For spinning **4/5 kg of vegetables** or **5/6 kg of leafy vegetables**
 - Two cycles for all types of vegetables: “automatic” which alternates rotation (450 rpm) with several sudden stops; “manual” thanks to the adjustable timer 0-59 min
 - Asynchronous industrial motor** for long life and silent operation
 - Safety:** the motor stops when the lid is opened
 - Flat and waterproof control panel (IP55)



EL40

ELX65

- 
End Users: Restaurants / Catering Facilities / Central Kitchens
 - From 200 to 500 covers**
- 
Main use: Spinning of all vegetables and herbs, lettuce, spinach, parsley, leeks
- 
 - For spinning in **2 minutes 10 kg of vegetables** or **10/15 kg of leafy vegetables** (330 rpm)
 - Asynchronous industrial motor** for long life and silent operation
 - Safety:** the motor stops when the lid is opened
 - Flat and waterproof control panel (IP55)
 - Stainless steel or resin baskets as option**



ELX65

Model	Capacity Heavy veg.	Capacity Lettuce heads	Basket volume	Dimensions (WxDxH)	Power
EL40	5 kg	9	32 lt	460x540x800 mm	370 W
ELX65	10 kg	18	65 lt	578x639x1005 mm	750 W



Flat and waterproof control panel (IP55)



Stainless steel/aluminum drying basket



Residual water drain



BREAD SLICER



Precision:
Blade specifically designed to avoid crushing the bread



Separator to cut 2 baguettes at the same time



Patented safety device prohibits access to the blade



Flat and waterproof control panel



- **End Users:** Restaurants / Catering facilities / Canteens
- **From 50 to 500 covers**



- Versatile and easy to use single chute electric bread slicer
- Optimum result: **adjustable slice thickness from 8 to 60mm**
- Patented safety device **prohibits access to the blade** during cleaning operations
- **Asynchronous industrial motor** for long life and silent operation

Dough kneaders

Complementary products for your kitchen.



- **End Users:** Pizzerias / Bakery/ Pastries
- **From 8 to 50 kg** of dough per cycle (depending on models)



- 1 and 2 speeds spiral dough kneaders with **10 to 62 lt bowl capacity**
- **Transparent screen to avoid the emission of flour into the work area** and to add ingredients without stopping the machine.
- Rounded bottom **stainless steel bowl** facilitates cleaning (fixed bowl)
- AISI304 stainless steel mixing arm/hook and dough breaker bar
- With braked wheels: easy to move and store away.
Fits under standard kitchen worktops.
- Tilting head and removable bowl models DSKTH available from 22 to 42 liters.



DSK

DSKTH

Gross bowl capacity (lt)	10 lt	22 lt	33 lt	42 lt	53 lt	62 lt
Available with tilting head and removable bowl (DSKTH)	No	Yes	Yes	Yes	No	No
Max kg of flour/cycle, for dough at 60% hydration	5 kg/cycle	10,6 kg/cycle	15,6 kg/cycle	20,6 kg/cycle	26,2 kg/cycle	31,2 kg/cycle
Max kneading capacity in kg of dough at 60% hydration	8 kg/cycle	17 kg/cycle	25 kg/cycle	33 kg/cycle	42 kg/cycle	50 kg/cycle
Minimum kneading capacity in kg of dough at 60% hydration	5 kg/cycle	9 kg/cycle	15 kg/cycle	19 kg/cycle	23 kg/cycle	27 kg/cycle
Speed	1	2	2	2	2	2
Timer (digital)	No	1 mechanical	1 mechanical	1 mechanical	1 mechanical	1 mechanical
Phases	1N	3	3	3	3	3



DOUGH SHEETERS

Allows the working of all types of lining pastry and dough.



- **End Users:** Restaurants / Catering Facilities / Small Kitchens and Bakeries



- Manual dough sheeter - table top model
- Compact and easy to move
- Cylinders are **teflon coated** (Ø 60 mm)
- Working width: **400 mm**. Dough thickness: **0,1 to 28 mm**
- Removable stainless steel slides / flaps



LMP400



- **End Users:** Restaurants / Catering Facilities / Small Kitchens
- Up to 300 settings



- Motorized dough sheeter - table top model
- **Wire safety screen**
- **Teflon coated** removable flaps facilitate the sliding of the dough
- Chrome plated steel cylinders (Ø 60 mm) may be adjusted depending on the thickness requested. Thickness **0,1 to 34 mm**
- Working width: **500 mm**
- Manual lever to invert cylinder rotation
- Flour container fixed on the top of the machine
- Remote foot pedal to change rolling direction (optional accessory)
- Optional trolley available
- **Asynchronous industrial motor** for long life and silent operation



LMP500



LMP500BT



- **End Users:** Large Catering Facilities / Small Central Kitchens
- **Up to 1000 settings**



- Motorized belt dough sheeters - table top and floor standing models
- Models with **1 speed** or **variable speed**
- Tables can be raised to **save space**
- **Wire gratings** with safety microswitch to stop motor if raised over a particular level
- **Teflon coated** removable slides facilitate the sliding of the dough
- Chrome plated steel cylinders (Ø 60 mm) may be adjusted depending on the thickness requested
- Manual lever to invert cylinder rotation
- Working widths: **500 mm** or **600 mm** (depending on model)
- Flour container fixed on the top of the machine
- Remote foot pedal to change rolling direction (optional accessory)
- **Asynchronous industrial motor** for long life and silent operation



Remote foot pedal (optional)



Cutting module for croissants (optional on selected models)



LMP600BT



VACUUM PACKERS

A range of **intuitive, easy to use, plug & play** table-top models. Digital and touch screen solutions as well as free-standing units for high productivity.

Plug & Play

No calibration needed thanks to the absolute type sensor

Printer connection

Print and customize your labels with the wireless printer for HACCP compliance.

Download the LabelPrint App



Android



Apple iOS



H2Out

Oil dehumidification cycle recommended to run daily. It preserves the pump for best working efficiency.

Touch control panel

intuitive waterproof scratch-resistant

Inert gas function

Delicate foods will not be compressed.

4 Gourmet cycles

Marinades in containers • Marinade in bags • Sauces and condiments • Spices and powders



Marinade in containers/bags



Sauces and condiments



Spices and powders



• **End Users:** Restaurant / hotel / deli shops / take away / supermarket / butcher shop



• **Main use: Extend food shelf-life and reduce food waste.** Prepare food in advance and increase your menu with less frequently used ingredients.



- **Storage control, HACCP ensured:** improve storage space by stacking different foods while avoiding cross-contamination of ingredients, dehydration, freezer burn and molds. Track your production and monitor your storage thanks to the wireless label printer.
- **Time and labor saving:** optimize kitchen workflow during workload peaks, while optimizing workforce during off-peak moments. Marinades and infusions are now made in only a few minutes enhancing flavours, aromas and fragrances. Cook sous-vide thus preserving texture, colours, nutrients and reducing weight loss.
- **Money saving:** buy larger quantities at lower price and vacuum pack in smaller quantities.



Table top TOUCH



Table top DIGITAL



Floor standing

Model	DVP20T	DVP08D	DVP12D	DVP16D	DVP25D	DVP60D
Pump	20 m ³ /h	8 m ³ /h	12 m ³ /h	16 m ³ /h	25 m ³ /h	60 m ³ /h
Sealing bar	410 mm	310 mm	310 mm	410 mm	455 mm	2 x 620 mm (front & rear)
Filling boards	3	2	2	3	3	3
Max. bag size inside chamber	400 x 450 mm	300 x 350 mm	300 x 400 mm	400 x 450 mm	450 x 550 mm	variable

Make your work **easier and more efficient** with a range of optional **accessories**



wireless label printer



stainless steel trolley



inclined filling tables



UK power cord



Etablissement Aubusson
Z.I. Du Mont - 23200 Aubusson
France

+33 (0)5 55 83 23 23 Tel
+33 (0)5 55 83 23 40 Fax



Discover the complete range at
ditosama.com



Follow [dito_sama_official](https://www.instagram.com/dito_sama_official)

Part of



Electrolux
Professional
Group