

Unitree

CONTENTS

About Us P1

Company Profile P1

Partner/Customer P2

Company Qualification P3

Company Honor P4

Software Platform P5

Sales & Service P6

Application P7

Example (I) P7

Example (II) P8

Example (III) P9

Product Introduction P10

A1 P10

Aliengo P12

Go1 P14

B1 P16

Z1 P18

Accessory P20

Joint Motor P20

Battery P21

Three In One P22

Parts P23

Company Profile

Founded in 2016, Unitree Robotics is a well-known company in the world of robotics, focusing on the R&D, production, and sales of consumer and industry-class high-performance quadruped robots, six-axis manipulators, and so on. Unitree is one of the earliest company in the world to publicly retail high-performance quadruped robots, and is a global leader in sales. We have a full set of professional instruments and equipment for R&D, production, and inspection to ensure the quality and stable performance of our products.



100+
PATENTS



5000+
CUSTOMERS



MILLION
INVESTMENT



QUADRUPED ROBOT
FAMOUS

Company Partner/Customer

With self-developed core components, motion control algorithms, robot perception system, and other self-developed technologies, Unitree Robotics has cooperated with a number of top universities and industry-leading technology enterprises. It not only provides customers with technical support such as software development and mechanical programming, but also helps customers configure a lot of external equipment. Quadruped robots have been used in many application scenarios such as security inspection, ground exploration, and detection. At present, hundreds of brands are equipped with Unitree quadruped robot, and many application areas such as petrochemical, security, electric power and education use the mature product solutions and technical support of Unitree Robotics.



Company Qualification

After continuous innovation and attempts, the company has created world-class products. It has obtained a number of authorized patents at home and abroad. Some products have been verified by SGS, a famous international certification organization, and have obtained EU CE, Japanese TELEC, American FCC, certifications. At the same time, it has obtained the international market access permit, becoming one of the leading enterprise in China to pass these standard certifications.



Company Honor

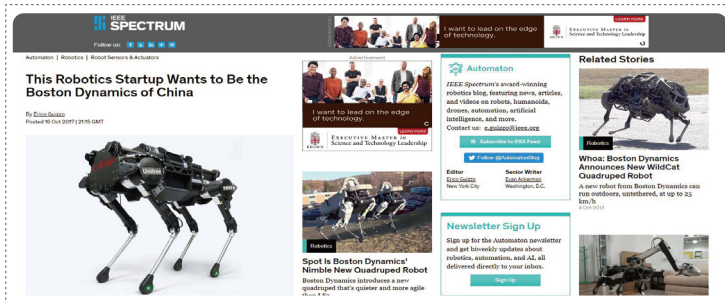

Laikago’s debut appeared on the front page of IEEE SPECTRUM of IEEE, and A1, Go1, AlienGo and Z1 were published many times.

Procurement of internationally renowned universities: Tsinghua University, Peking University, ETH Zurich, Leeds University, University of Tokyo, etc; Invited to participate in the international top robot conference ICRA from 2018 to 2021, and did the Legged Robot Forum Presentation (MIT, Eth and BD participated in the same period); It has been concerned and reported by CCTV news, People’s Daily, Reuters, Agence France Presse and other authoritative media at home and abroad.

On February 4, 2022, at the opening ceremony of the Beijing Winter Olympic Games, 109 “Fu tigers” lined up in the [Winter Olympic Games] queue and danced enthusiastically, integrating scientific and technological elements with the festive atmosphere. CCTV explained that this move conveyed the spirit and power of “Science and Technology China, digital intelligence Hangzhou, standing at the forefront of the tide and looking to the future” to the world.

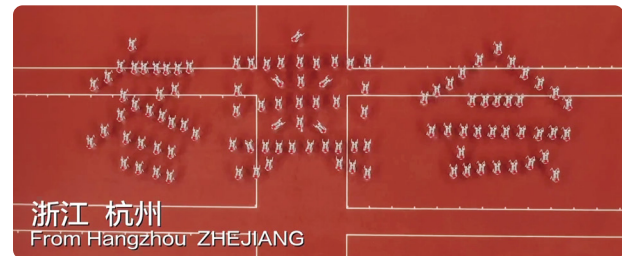
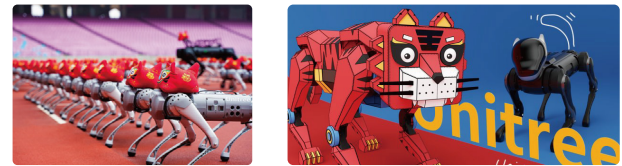

Software Platform

The user PC can directly connect the robot with Ethernet, with built-in airborne dual master control and bottom controller. The open high-level control can directly send high-level motion commands such as forward, backward, left and right movement to the robot. Convenient visual perception call mode, which can be used by developers for secondary development. The open bottom control can read and control all motors and sensors of the robot in real time, which is convenient to directly use the open source robot algorithm. The data transmission and image transmission with low delay can realize the real-time mutual transmission of data.

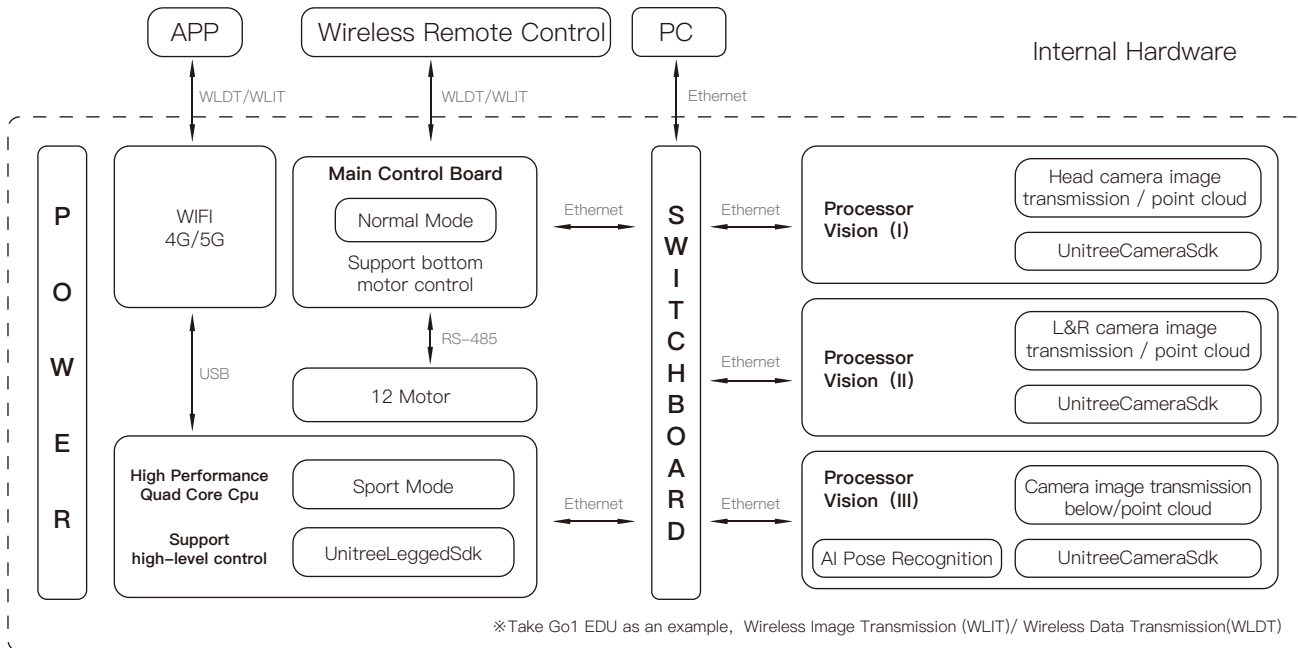

Sales & Service

In the process of globalization expansion, Unitree implements the “globalization” strategy, establishes localized sales teams, channels and service partners, and provides products and services in local languages to meet customer needs and habits and realize the localization of teams and products. After-sales and support provide the most appropriate service scheme and the best service quality to maximize the system availability and system efficiency.



- 🕒 7x24h Service
- 🔧 Technical Support
- 🎓 Training & Authorization
- 🔄 Remote Technical Support
- 📦 System Maintenance & Upgrade
- 🛠️ Spare Parts Supply

2013

- The world's pioneering independent development of a full degree of freedom high-performance quadruped robot xdog driven by a low-cost external rotor brushless motor.



XDog

2016

- Founded Unitree Robotics;
- The reconstructed quadruped robot laikago came out (from Laika, a space dog).



Laikago

2019

- Release aliengo quadruped robot, which is positioned as a functional quadruped robot in the industry. It adopts a newly designed power system, lighter weight integration and integrated fuselage design.



Aliengo

2020

- Unitree A1 is small, flexible and explosive. Its maximum continuous outdoor running speed can reach 3.3m/s. It is the fastest and most stable small and medium-sized quadruped robot, which further promotes the process of quadruped robot entering public life.



A1

2021

- Released go1, with its ultra-low price breaking through the industry limit and excellent perceptual movement ability, it has become one of mobile robot to truly enter public life in the history of human science and technology.

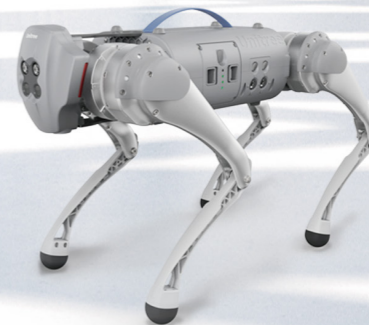

Go1

2021

- Release B1, protection grade IP68, focus on industrial landing, industrial super large load, dust-proof and waterproof.



B1

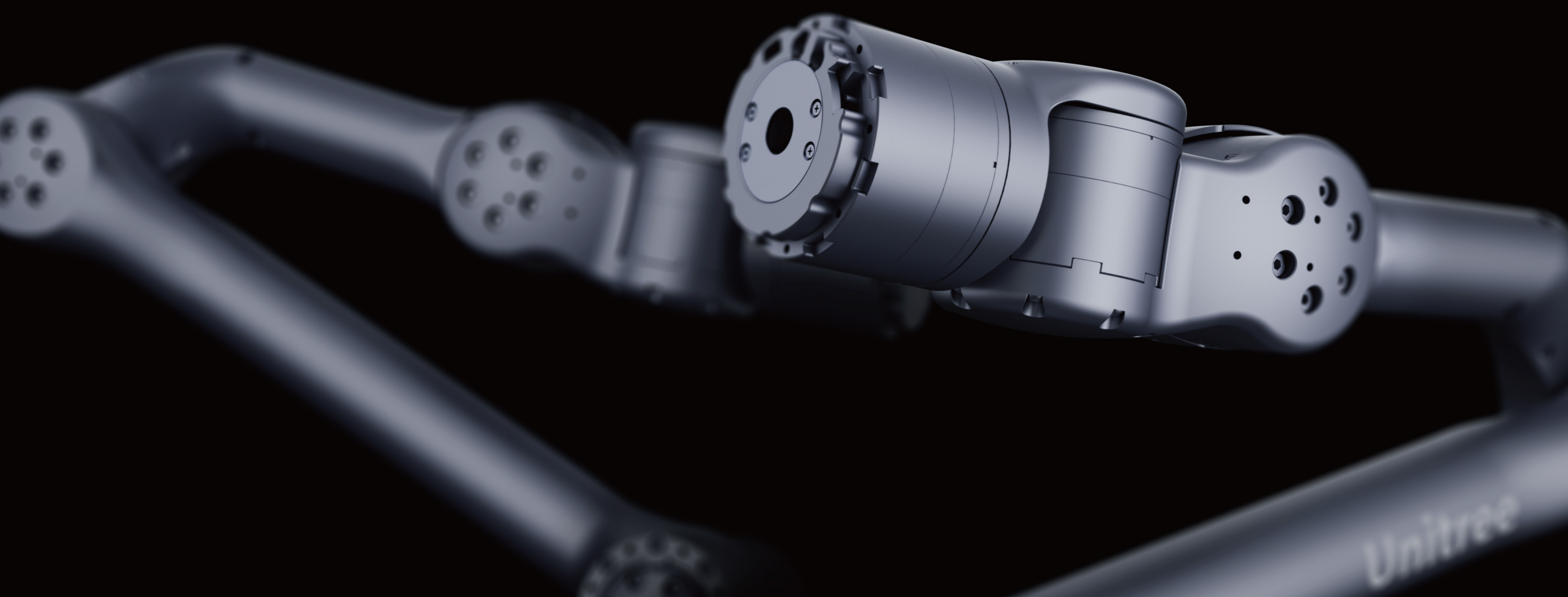

Unitree

Example (I)

Compared with traditional inspection robots (wheeled and tracked), quadruped robots have discrete footholds and can adapt to different terrain, such as stairs, steps, slopes, mountains and so on. Equipped with GPS, robotic arm, lidar and other instruments and testing equipment, they can complete a series of work (intelligent construction, survey, search and rescue, security patrol, etc.), and provide patrol inspection, exploration, material transportation and other work and services for petrochemical, electric power, railway and mineral collection.

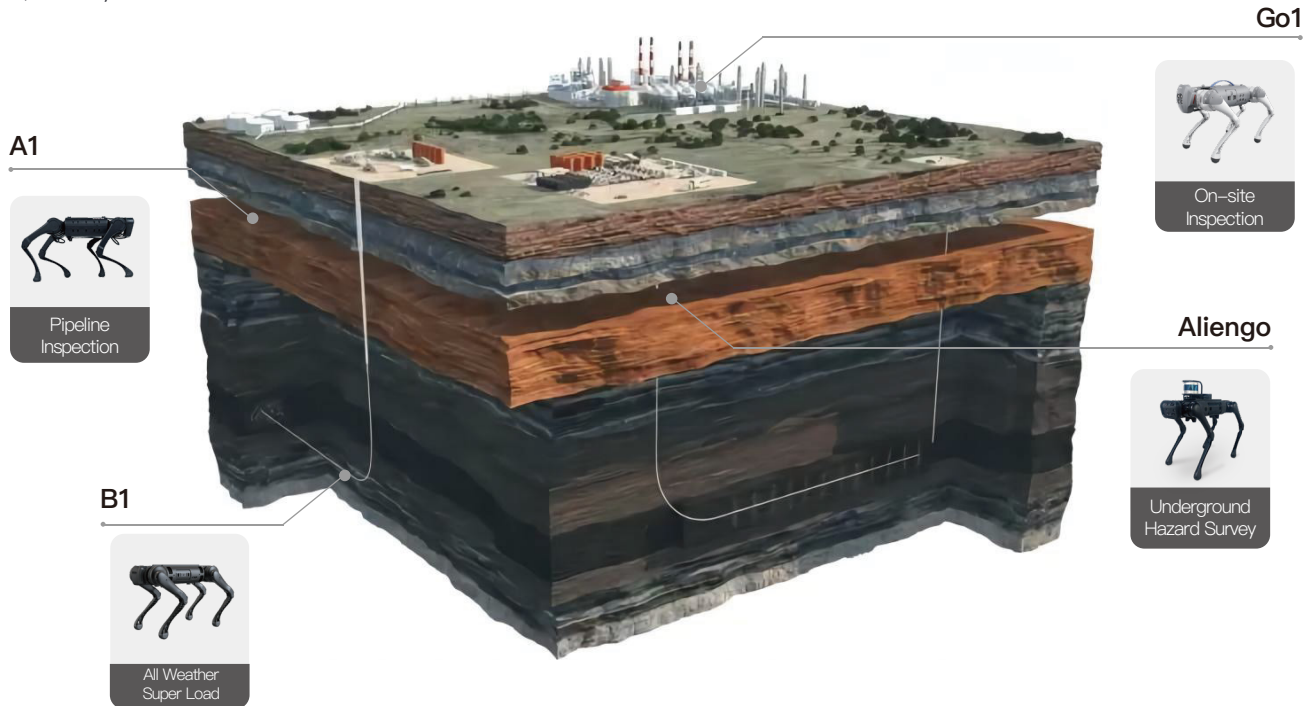

Example (II)



It can be equipped with GNSS, manipulator, lidar and other instrument detection equipment to complete a series of work.



Thanks to the good reliability and stability of the whole machine, it has strong adaptability to irregular terrain.



The discrete foothold of the legged robot and unitree's self-developed multi-vision technology can quickly go up and down stairs.



Provide patrol inspection, exploration and material transportation for petrochemical, electric power, railway and mineral collection.



The police robot dog is flexible and free from environmental restrictions, and solve the difficulties of inspectors, improving the inspection efficiency and reducing the manpower investment.

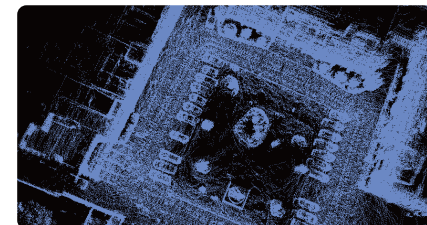

Equipped with 3D imager, it can quickly build high-definition plan and 3D model map of the target area to provide information support for on-site command.

Example (III)



OUR TOP STORIES OF 2021

NVIDIA Developer aim to provide clarity and understanding on the role of dynamics randomization in learning robust locomotion policies for the Laikago quadruped robot. This work will be presented at ICRA 2021.

Researchers from UC Berkeley, Carnegie Mellon University, and Facebook AI have created a new algorithm: Does not require any reference trajectory, directly deployed on the robot without fine-tuning—it can make them adapt to various complex new terrains in an instant, and walk through the environment such as rocks, beaches, stairs, long vegetation, artificially built movable boards, etc. without taking a step.

Robot Competition

Promote the innovation and application ability of intelligent robot technology, and provide support for colleges and universities engaged in research in the field of artificial intelligence and robot through a variety of competition modes such as cutting-edge technology simulation competition, intelligent robot field competition and innovative technology road-show competition.



A1 More Dexterity, More Possibilities

Dexterous & Professional

The product weight is only 12kg, but the leg motor, which has 33.5n M explosive force, can achieve rapid recovery posture under imbalance.

Ultimate Patented Power System

The ultimate power system brings the ultimate sports performance.



CE FC RoHS

Patented Fuselage Structure Layout Design

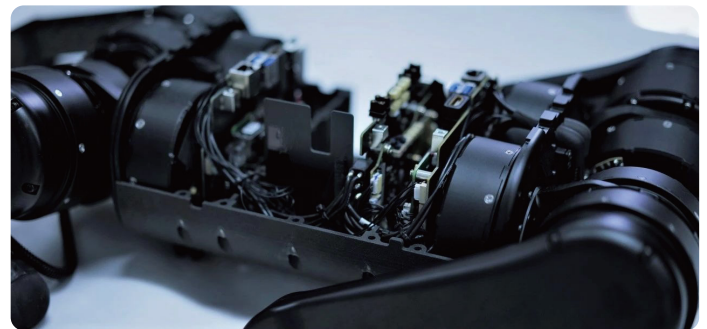

- 24V external power input interface, 5V, 12V and 19V external output power supply, which is convenient for external connection of various expansion equipment.
- The standard configuration is high-performance airborne dual master control (perception master control and motion master control), including external interfaces : USB×4, HDMI×2 and Ethernet×2.

Technical Parameter

Size	500mm×300mm×400mm (Stand) 450mm×300mm×150mm (Fold) L×W×H
Weight	12kg
Payload	5–7kg
Max Speed	3.3m/s
Endurance	1–2.5h
Slope	35°
External Interface	HDMI×2, Ethernet port×2, USB 3.0×4
Power Interface	5V, 12V, 19V
Depth Camera	1 Pair
Perceived Computing Power	Jetson Xavier NX
Research Programming Interface	Support
Python Programming Interface	Support
Rich Development Materials	Support

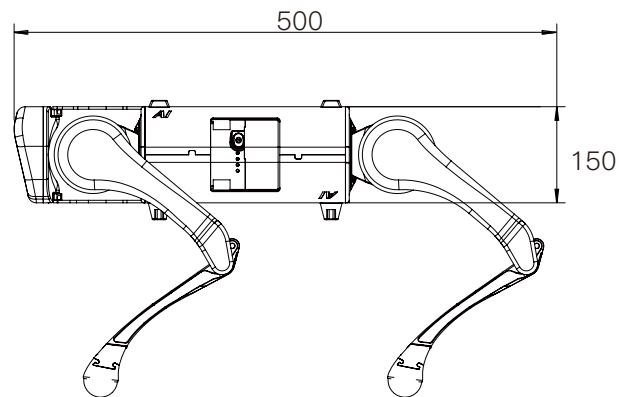
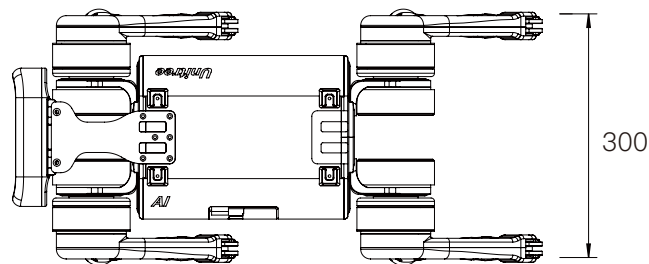

Aliengo New Integrated Design



Super Fuselage & Long Endurance

The self-developed power lithium battery pack has excellent endurance and the maximum running time can reach 4.5 hours.

Compound Control Of Joint By Force Control Technology

The 3-axis attitude and position are fully controlled, so it has strong multi-terrain adaptability and can operate stably on rugged gravel roads and grassland roads.

Depth Perception Vision

Depth camera

Global shutter and wide field of view
The minimum sensing depth is about 0.11m
Up to 1280 x 720 depth resolution.

Visual odometer camera

Highly optimized VSLAM, closed-loop offset is less than 1%, and the delay between attitude action and action reflection is less than 6 milliseconds. The fisheye lens imager, combined with the near hemispherical $163 \pm 5^\circ$ field of view, can move rapidly and track stably.



Technical Parameter

Size	650mm×310mm×600mm (Stand) 600mm×310mm×150mm (Fold) L×W×H
Weight	19±1kg
Payload	13kg
Max Speed	1.5m/s
Endurance	2.5–4.5h
Ladder Height	18cm
Slope	30°
External interface	HDMI×2, Ethernet port×2 USB 3.0×2, 485×1
External Power Interface	5V, 12V, 19V, 25.2V (BAT)
Sensing Sensor	Depth camera×2, visual odometer camera×1
Perceived Computing Power	Jetson Xavier
Research Programming Interface	Support
Python Programming Interface	
Support Remote Control	Support
Image Transmission Module	

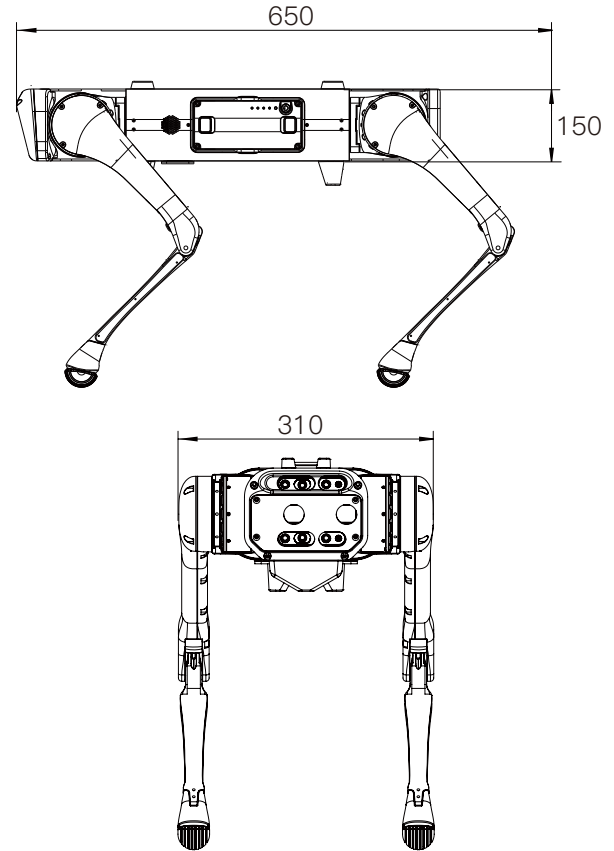

Go1 Go Wherever You Will Go



Intelligent Side-follow System

The robot walks alongside its human master within sight of the human, which is much better than the conventional following mode. Besides, the human-machine interaction is both harmonious and safe. No need to worry about the robot since it's right beside you. People are capable of helping robot choosing a better route in the complex environment.



Super Sensory System

Full View Coverage ;
5 Sets Fish-eye Stereo Depth Cameras + Ai Post-processing ;
Lens Angle $\approx 150 \times 170^\circ$



Built-in Powerful AI

16 core CPU + GPU(384Core, 1.5TFLOPS)

For reference, the Nvidia TX2 has CPU (4 cores) +GPU(256Core, 1.3TFlops) with price at 468+dollar.



Technical Parameter

Model	AIR	PRO	EDU
Size	645mm×280mm×400mm (Stand) 540mm×290mm×130mm (Fold) L×W×H		
Weight	12kg		
Payload	3kg	3kg	5kg(Limit~10kg)
Max Speed	2.5m/s	3.5m/s	3.7m/s(Limit~5m/s)
Endurance	1~2.5h		
Slope	35°		
External Interface	None	None	HDMI*3; Gigabit network port * 1; USB*3; Integrated interface * 1
Power	24 (BAT)		
SSS	1 Pair	5 Pair	5 Pair
Perceived Computing Power	1 * (4 * 1.43 GHz 128Core 0.5T)	3 * (4 * 1.43 GHz 128Core 0.5T)	2Nano + (1Nano or 1NX)
4G or 5G	None	None	4G (Standard) 5G (Optional)
Graphic Programming Interface	Support	Support	Support
Research Programming Interface & Python Programming Interface	None	None	Support
Lidar	None	None	2D or 3D (Optional)

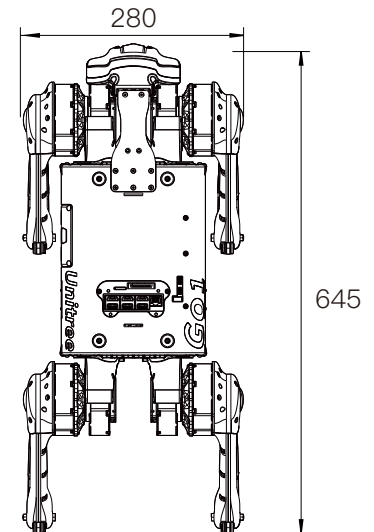
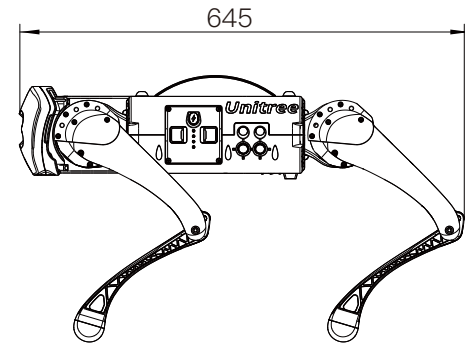

B1

Industrial Grade
Super Large Load
Dustproof & Waterproof

IP68

Protection Level



※: The waterproof grade shall not be lower than IP67

Technical Parameter

Size	1126mm×467mm×636mm (Stand) 1202mm×467mm×297mm (Fold) L×W×H
Weight	55kg
Max Walking Load (Continuous Working Load)	20kg
Max Standing Load	80kg
Max Speed	1.2m/s
Endurance	2-2.5h
Stairways	20cm
External Interface	Gigabit Network Port × 7, RS485 × 4, USB × 5, CAN × 4
External Power Interface	5V, 12V, 24V, 51V (BAT)
Remote Control Image Transmission Module	Support
Depth Camera	5 Pair
Perceived Computing Power	Jetson Xavier NX×3
Research Programming Interface Python Programming Interface	Support

Slope	30°
4G or 5G	Possess
Level	IP68 (optional) IP67 (standard)
GNSS	Support

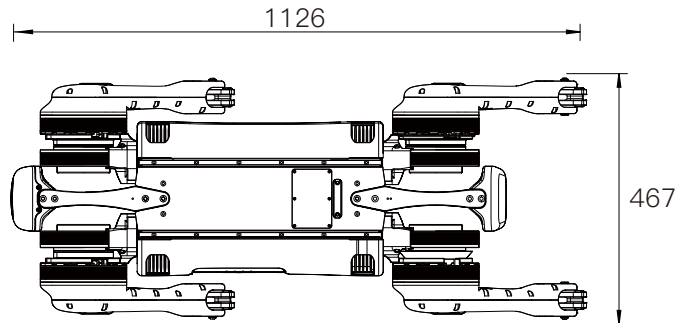
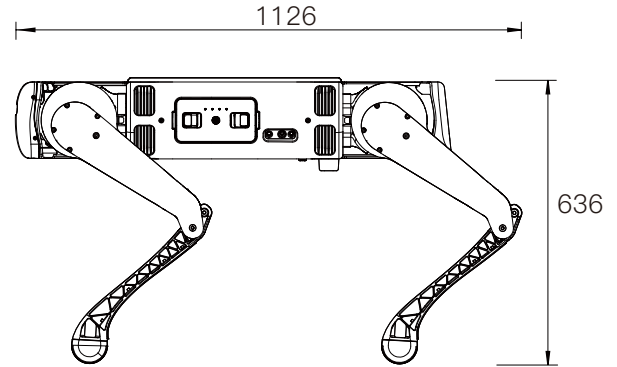

Z1 Dexterous Collaborative Robot

Open Programming Interface and Extended Interface

The manipulator control program and control interface will be successively opened, and different actuators can be quickly replaced at the end of the manipulator.



Application

Various mobile robots' onboard manipulator, e-commerce logistics, new consumption, daily life, etc.



Technical Parameter

Model	AIR	PRO
DOF	6	6
Weight	4.3kg	4.5kg
Payload	2 kg	≥3kg
Reach	740mm	
Repeatability	~0.1mm	
Power Supply	Voltage 24V Current > 20A	
Interface	Ethernet	
User Operating System	Ubuntu	
Power	MAX 500w	
Force Feedback Collision Detection	Support	
Control Interface	Position + Force Control	
Joint	Range	Max Speed
J1	±150°	180°/s
J2	0-180°	180°/s
J3	-165°-0	180°/s
J4	±80°	180°/s
J5	±85°	180°/s
J6	±160°	180°/s

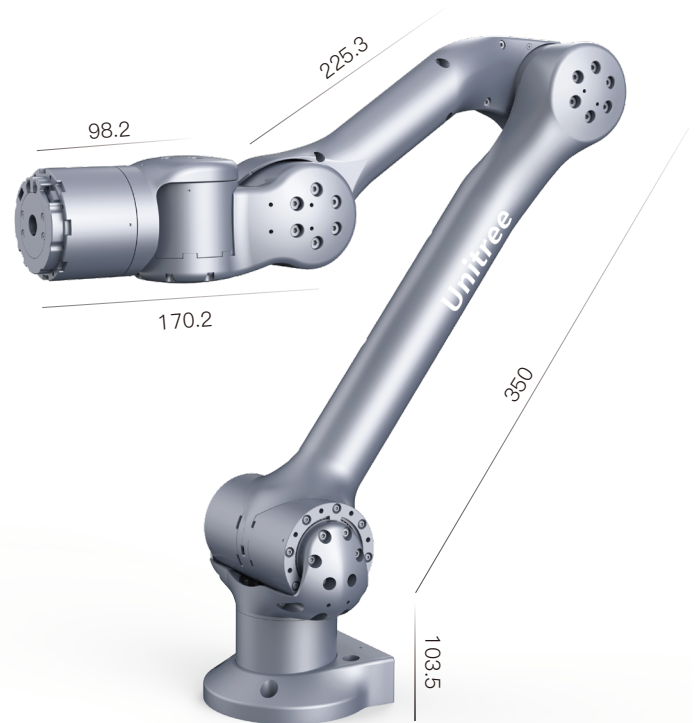

Joint Motor

A1



21rad/s
Max Joint Speed

33.5 N·m
Max Joint Torque



Super Robot Waterproof Joint



IP68
IP Grade

140.00 N·m
Max Instantaneous Torque



Go1



520g
Weight

23.7 N·m
Max Instantaneous Torque



Battery

The high-energy and high-voltage battery are specially customized for your robot uses polymer lithium-ion power cell to greatly improve the endurance time of the robot and meet all the needs of the routine operation of the robot. The intelligent battery management system (BMS) monitors the battery status at all times to ensure stable and safe operation.

A1



4200mAh



Aliengo



12600mAh



Go1



6000mAh



Three In One



High Power Searchlight



- Remote Independent Control Switch
- Up to 60w Power
- OSDK Interface
- Support the Camera to Follow or Independently Control
- Multiple Groups of Optical Lenses
- Four Control Modes of Cylindrical Light Emission
- Two-axis Mechanical Gimbal Stabilization

Warning Light Function



- Remote Independent Control Switch
- Support 12 Blinking Modes
- Double-sided Installation is More Eyecatching
- Good Waterproof and Anti-vibration Specification
- Mode Can be Adjusted Remotely
- Support External Protocol Control
- 25g Ultralight Weight On One Side

Parts



Dual-beam camera



Go1 Back Integrated Interface Expansion Module



Single Line Lidar



16 Wire Lidar



Voice Module



Remote Control with Screen (Dual Cameras)

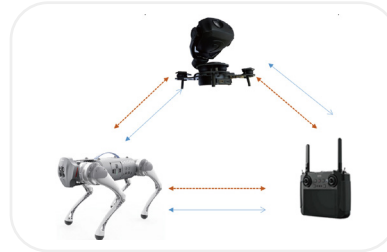

Dual Light Integrated PTZ
+
Remote Control with Screen

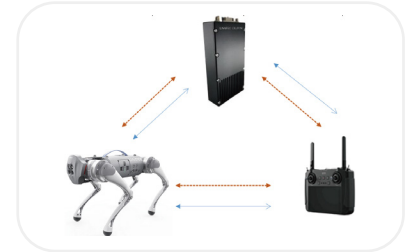

Self-organizing Network Detection
Robot Dog

Unitree

Web: www.unitree.com

Tel: +86 187 6713 8485

Email: laikago@unitree.cc



Follow us@Unitree Robotics